



EUROPEAN AVIATION SAFETY AGENCY
AGENCE EUROPÉENNE DE LA SÉCURITÉ AÉRIENNE
EUROPÄISCHE AGENTUR FÜR FLUGSICHERHEIT

10TH
ANNIVERSARY

OPS Workshop

Helsinki

26/02/2013

Daniela DEFOSSAR
Hervé JULIENNE

Your safety is our mission.
easa.europa.eu



Agenda Day 1

MORNING	Regulation 216/2008 – Development of opinions - Regulation 965/2012 Drafting principles	EASA
	Regulation 965/2012 – Cover Regulation – Overview of annexes	EASA
	Coffee break	
	Flight Time Limitations (FTL) CAT and future FTL work	EASA
LUNCH		
AFTERNOON	Entry into force – Transitioning – Grandfathering – Conversion of AOC	EASA
	Alternative means of compliance and AMC process	EASA
	Volcanic Ash - EFB	EASA
	Coffee break	
	Other on-going EASA Rulemaking tasks	EASA
	Implementation in Finland	CAA-FI



EUROPEAN AVIATION SAFETY AGENCY
AGENCE EUROPÉENNE DE LA SÉCURITÉ AÉRIENNE
EUROPÄISCHE AGENTUR FÜR FLUGSICHERHEIT

10TH
ANNIVERSARY

- **Regulation (EC) No 216/2008**
- **Rulemaking process**
- **Drafting principles Regulation (EU) No 965/2012**

Your safety is our mission.
easa.europa.eu



Basic regulation (BR)

The BR is part of the EU air transport regulatory framework.

Reg 1008/2008 Operation of air services	Reg 785/2004 Insurance	Dir 2002/30/EC Noise at airports	Reg 96/67/EC Ground handling	Dir 2009/12/EC Airport charges
Reg 95/1993 Slot allocation	Reg 261/2004 Denied boarding	Dir 92/14/EEC Limitation of operation of aeroplanes	Reg 549- 552/2004 SES	Dir 2004/36/EC 3 rd country aircraft
Reg 889/2008 Air carrier liability	Reg 1107/2006 Disabled persons	Reg 2111/2005 Black list	Reg 219/2007 SESAR	Reg 216/2008 Aviation safety
Reg 300/2008 Security	Security IRs	Dir 2003/42/EC Occurrence reporting	Reg 996/2010 Accident investigation	etc.



Territorial scope of the BR

Validity of the BR



27 EU states



4 EFTA states





Material scope of the BR

BR covers:

Airworthiness and environmental protection of aircraft

- Pilots
- Air operations
- Aerodromes
- ATM/ANS and Air Traffic Controllers

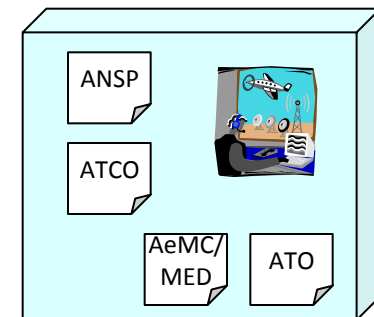
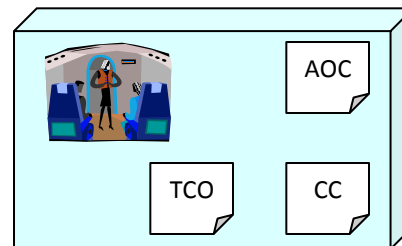
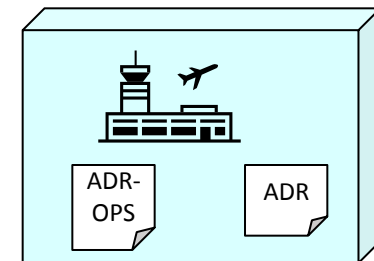
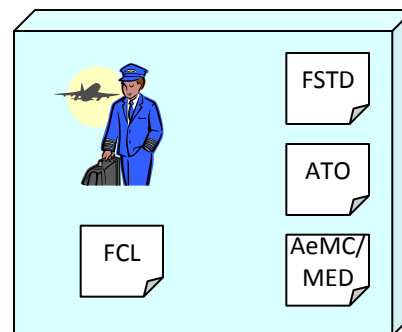
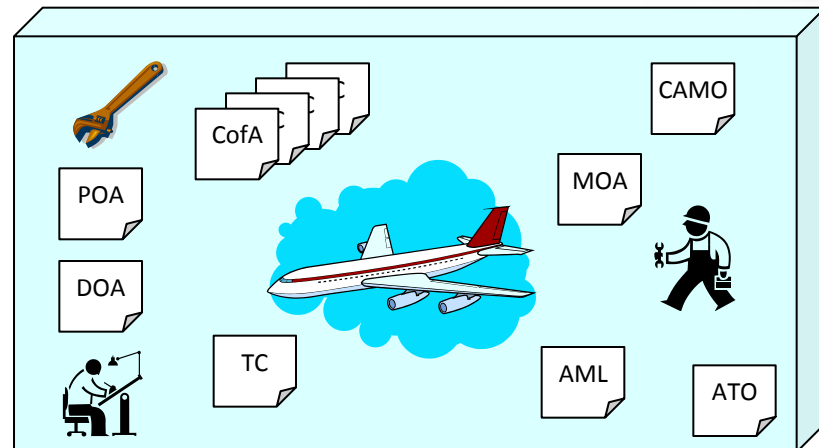



Material scope of the BR

BR does not cover:

Airworthiness and environmental protection of aircraft	<ul style="list-style-type: none">- while carrying out military, customs, police, SAR, fire fighting, coastguard or similar services- when referred to in Annex II
Pilots and operations	<ul style="list-style-type: none">- of aircraft referred to in Annex II, unless used for commercial operations
Aerodromes	<ul style="list-style-type: none">- that are controlled and operated by the military- not open to the public, not serving commercial air transport, not providing operations using instrument approach or departure (or) having paved runway of less than 800m (unless exclusively serving helicopters)
ATM/ANS	<ul style="list-style-type: none">- that are provided or made available by the military

Consequence: The national rules apply.



Basic regulation (BR)

BR provides common rules in Europe for civil aviation:

- Principles (Art. 1–3)
- Substantive requirements (Art. 4–16)
- EASA (Art. 17–64)
 - Tasks
 - Internal structure
 - Working methods
 - Financial requirements
- Final provisions (Art. 65–70)

19.3.2008	EN	Official Journal of the European Union	L 79/1
I			
(Acts adopted under the EC Treaty/Euratom Treaty whose publication is obligatory)			
REGULATIONS			
REGULATION (EC) No 216/2008 OF THE EUROPEAN PARLIAMENT AND OF THE COUNCIL of 20 February 2008 on common rules in the field of civil aviation and establishing a European Aviation Safety Agency, and repealing Council Directive 91/670/EEC, Regulation (EC) No 1592/2002 and Directive 2004/36/EC (Text with EEA relevance)			
THE EUROPEAN PARLIAMENT AND THE COUNCIL OF THE EUROPEAN UNION,		the limits set by the Convention on International Civil Aviation, signed in Chicago on 7 December 1944 (the Chicago Convention), to which all Member States are parties.	
Having regard to the Treaty establishing the European Community, and in particular Article 80(2) thereof,			
Having regard to the proposal from the Commission,	(3)	The Chicago Convention already provides for minimum standards to ensure the safety of civil aviation and environmental protection relating thereto. Community essential requirements and rules adopted for their implementation should ensure that Member States fulfil the obligations created by the Chicago Convention, including those vis-à-vis third countries.	
Having regard to the Opinion of the Economic and Social Committee (1),			
After consulting the Committee of the Regions,			
Acting in accordance with the procedure laid down in Article 251 of the Treaty (2),	(4)	The Community should lay down, in line with standards and recommended practices set by the Chicago Convention, essential requirements applicable to aeronautical products, parts and appliances, to persons and organisations involved in the operation of aircraft, and to persons and products involved in the training and medical examination of pilots. The Commission should be empowered to develop the necessary implementing rules.	
Whereas:	(5)	It would not be appropriate to subject all aircraft to common rules, in particular aircraft that are of simple design or operate mainly on a local basis, and those that are home-built or particularly rare or only exist in a small number; such aircraft should therefore remain under the regulatory control of the Member States, without any obligation under this Regulation on other Member States to recognise such national arrangements. However, proportionate measures should be taken to increase generally the level of safety of recreational aviation. Consideration should in particular be given to aeroplanes and helicopters with a low maximum take-off mass and whose performance is increasing, which can circulate all over the Community and	
(1) OJ C 185, 8.8.2006, p. 106.			
(2) Opinion of the European Parliament of 14 March 2007 (OJ C 301 E, 13.12.2007, p. 103), Council Common Position of 13 October 2007 (OJ C 277 E, 20.11.2007, p. 8) and Position of the European Parliament of 12 December 2007, Council Decision of 31 January 2008.			

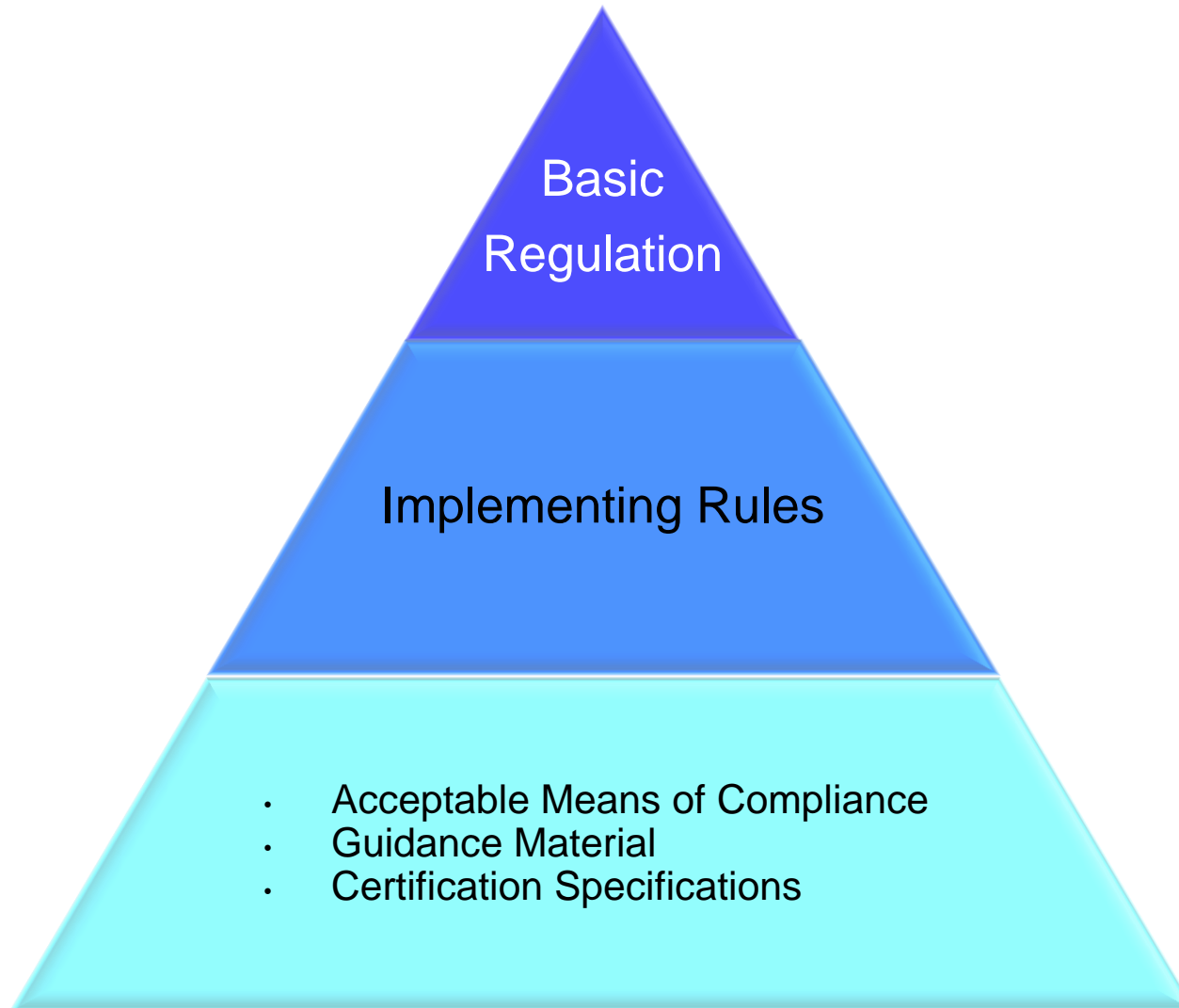

► Legislator:

1) European Parliament and Council



upon proposal from the European Commission

2) European Commission



- European Parliament and Council may delegate to the Commission power to adopt Delegating Acts
- Commission is granted power to adopt Implementing Acts

- EASA supports the European Commission by providing drafts for such legislation
- Drafts are provided as Agency opinions



- Agency opinions are developed in accordance to its Rulemaking Procedure (Decision of the MB)



Development of opinions





Development of opinions

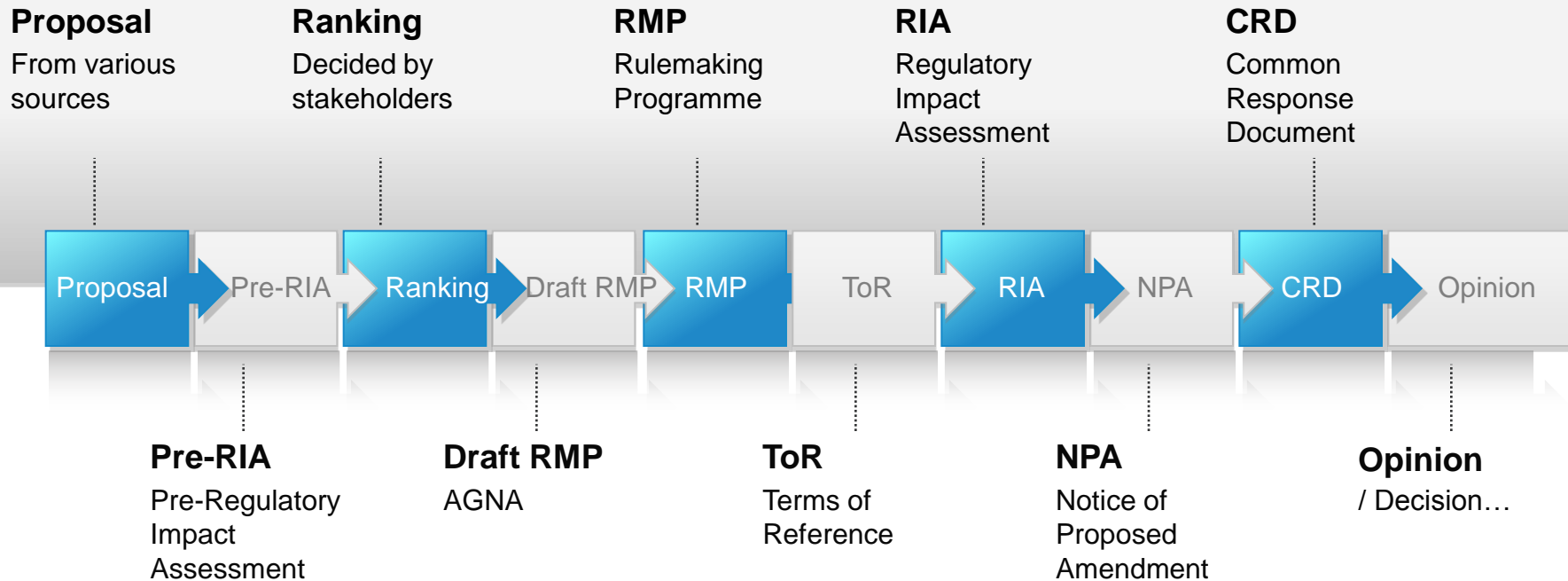

European aviation rule structure

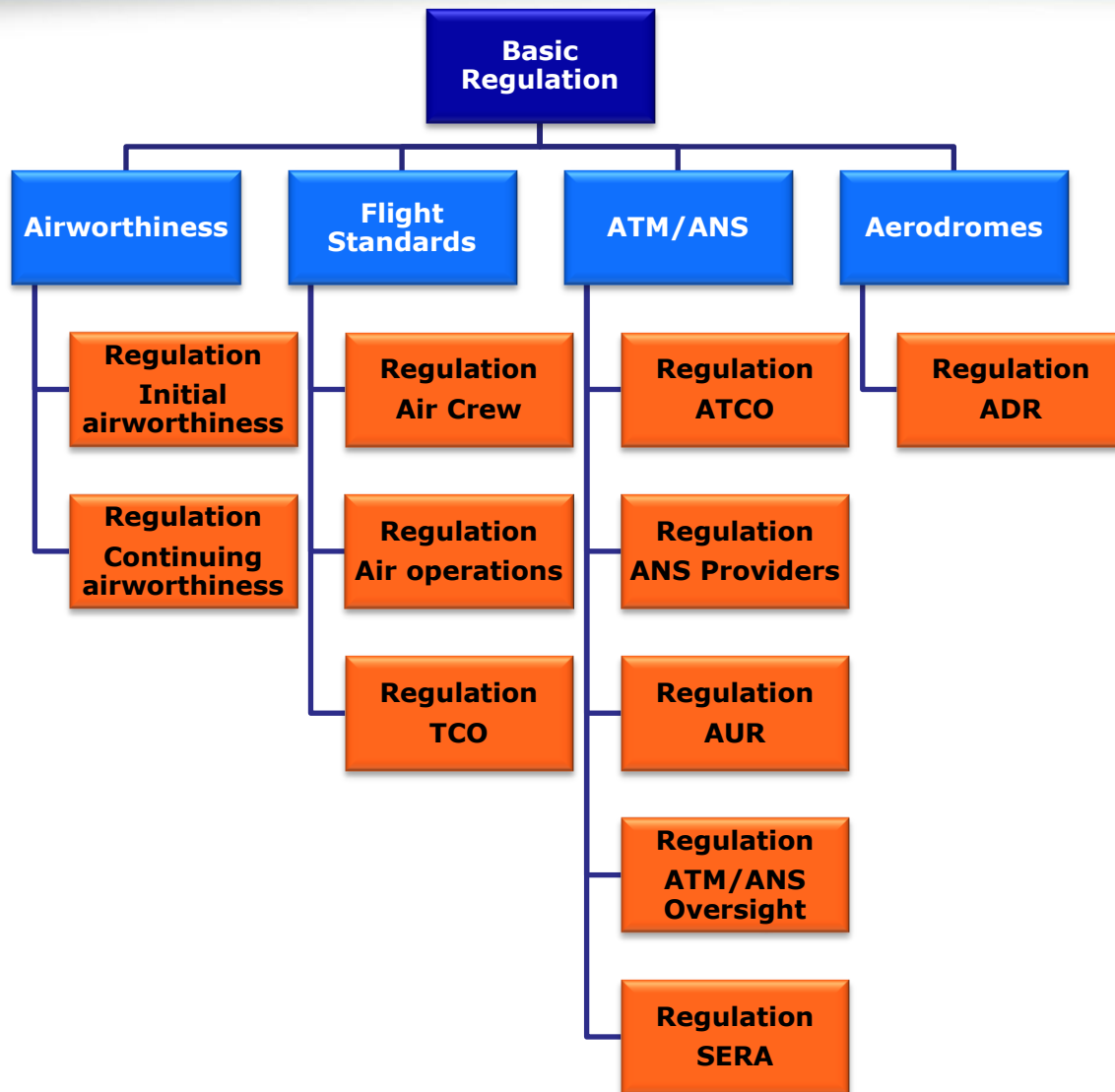

- **ATM/ANS:** Air traffic management, air navigation services
- **TCO:** Third country operators
- **ATCO:** Air traffic controllers
- **AUR:** airspace usage requirements
- **SERA:** Single European rules of the air
- **ADR:** Aerodromes



OPS rule structure and rule development

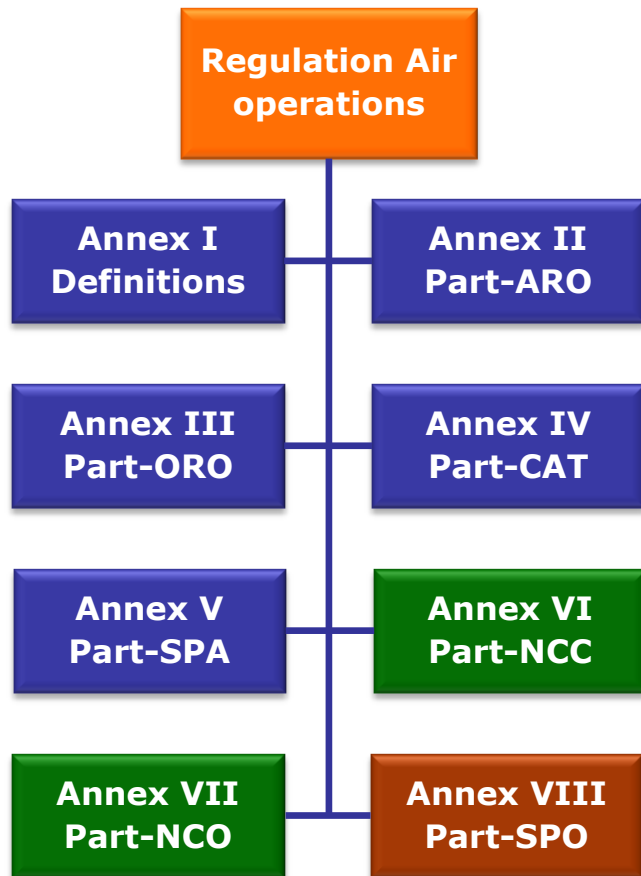

Regulation 965/2012 + Decisions 2012/15-16-17-18-19/R

- **Part-ARO:** Authority requirements - OPS
- **Part-ORO:** Organisation requirements - OPS
- **Part-CAT:** Commercial air transport operations
- **Part-SPA:** Operations requiring specific approvals

Opinion 01/2012

- **Part-NCC:** Non-commercial operations with complex motor-powered aircraft (CMPA)
- **Part-NCO:** Non-commercial operations with other than CMPA

Opinion 02/2012

- **Part-SPO:** special operations (e.g. aerial work)



Basic Regulation Article 3 item (j)

'complex motor powered aircraft' shall mean:

An aeroplane:

- with a maximum certificated take-off mass exceeding 5 700 kg, or
- certificated for a maximum passenger seating configuration of more than 19, or
- certificated for operation with a minimum crew of at least two pilots, or
- equipped with (a) turbojet engine(s) or more than one turboprop engine.

A helicopter certified:

- for a maximum take-off mass exceeding 3 175 kg, or
- for a maximum passenger seating configuration of more than nine, or
- for operation with a minimum crew of at least two pilots.



OPS rule structure and rule development

Rule development	Phase OPS I	Phase OPS II	Phase OPS III	Phase OPS IV
Cover Reg.	initial version	amendment	amendment	amendment
Definitions	initial version	amendment	amendment	amendment
Part-ARO	initial version	amendment	amendment	amendment
Part-ORO	initial version	amendment	amendment	amendment
Part-CAT	A, H			S, B, A-to-A
Part-SPA	initial version	amendment		
Part-NCC		initial version		
Part-NCO		initial version		
Part-SPO			initial version	

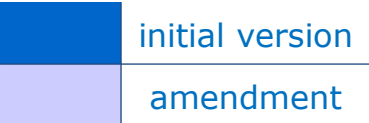

initial version
amendment



OPS rule structure and rule development

Document Status	Published: Reg. 965/2012	Adopted in EASA Committee	Discussed in EASA Committee	Discussed in EASA Committee
	Phase OPS I	Phase OPS II	Phase OPS III	Phase OPS IV
Cover Reg.				
Definitions				
Part-ARO				
Part-ORO				
Part-CAT	A, H			S, B, A-to-A
Part-SPA				
Part-NCC				
Part-NCO				
Part-SPO				

IR:

- Rule development finalised
- IR to be published in the Official Journal

AMC/GM:

- Rule development at final stage
- To be published together with IR



OPS rule applicability

Rule applicability	CAT operator	NCC operator	NCO operator	SPO operator	NAA
Cover Reg.					
Definitions					
Part-ARO					
Part-ORO				Com/non-com CMPA	
Part-CAT					
Part-SPA					
Part-NCC					
Part-NCO					
Part-SPO					



OPS rule structure

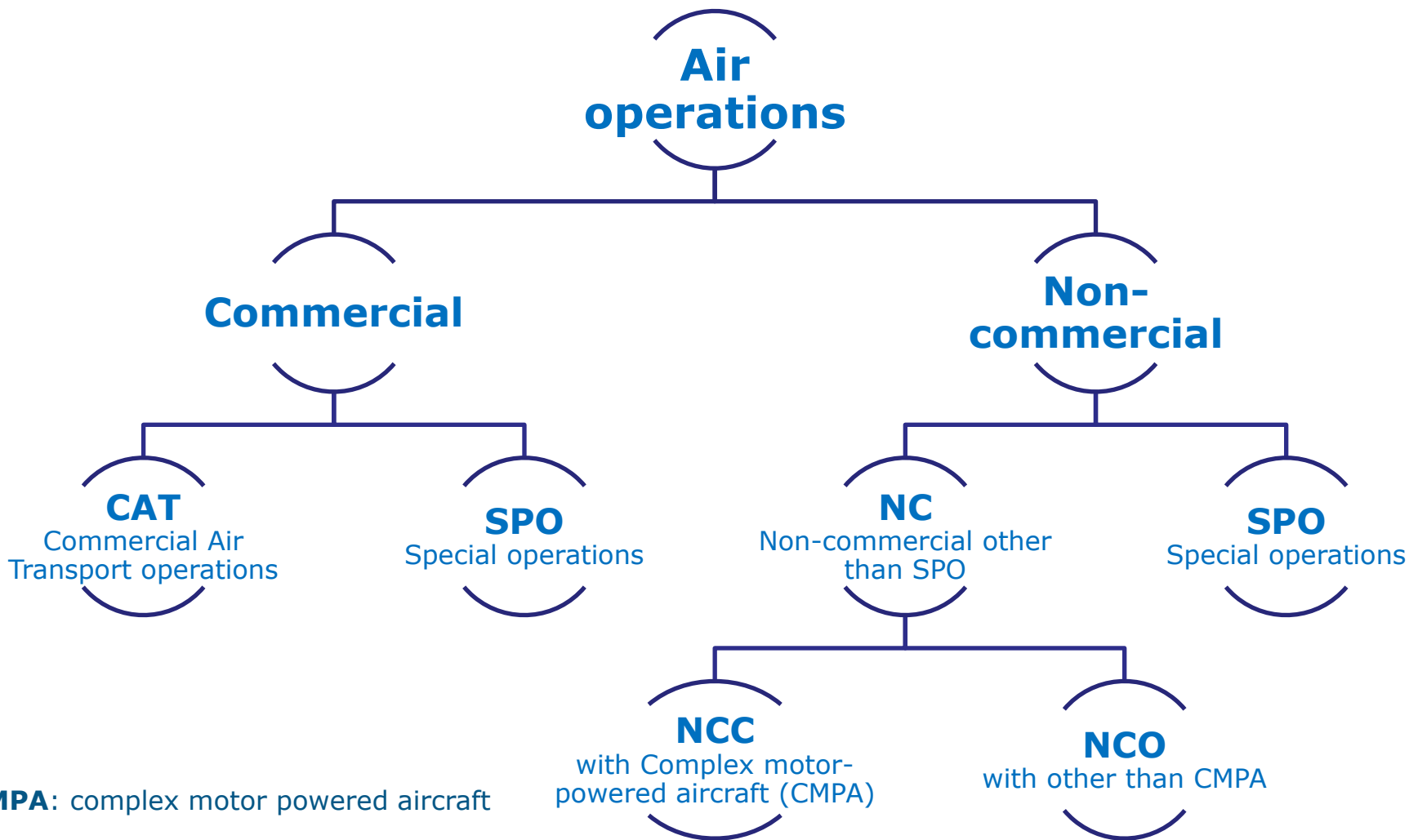

CMPA: complex motor powered aircraft

➤ **Safety focus**

- Risk-based approach.
- Emphasis on SMS and oversight capabilities.
- Strengthening operator and authority responsibilities.

➤ **Harmonisation**

- ICAO compatibility.
- Harmonised rules with other regional regulators, e.g. FAA, TCAA.

➤ **Flexibility and efficiency**

- Safety objective – Implementing Rule level.
- Method to comply with safety objective – AMC level.
- Operator can develop its own alternative AMC.
- Specific operational or geographical needs can be addressed.
- Proportionality.

- **Proportionality: CAT rules differentiate between; (1/2)**
 - Organisation;
 - non-complex versus complex organisations.
 - Nature of operation;
 - local/A-to-A versus A-to-B operations.
 - Flight rules;
 - IFR and night versus VFR operations.
 - Crew;
 - single-pilot versus multi-pilot operations,
 - operations with cabin crew versus operations without cabin crew.

- **Proportionality: CAT rules differentiate between; (2/2)**
 - Aircraft;
 - non-complex aircraft versus complex aircraft,
 - single-engined aircraft versus multi-engined aircraft,
 - performance classes A, B and C for aeroplanes,
 - performance classes 1, 2, 3 and categories A and B for helicopters.

➤ **For transposing EU-OPS and JAR-OPS 3**

- Rules with a safety objective are transposed as IR.
- Rules with a means to comply with a safety objective are transposed as AMC,
 - following this principle, most Appendices have been transposed as AMC.
- Rules which could not obviously be classified as safety objective or means to comply are transposed as IR.
- Notes and rules with explanatory character are transposed as GM.
- Appendices with alleviations: 1.005(a), 3.005(f), 3.005(g) have been transposed into the applicable rules, where relevant.

- **For transposing EU-OPS and JAR-OPS 3 (cont.)**
 - Rules allowing an alternative if approved/accepted by the authority have been removed and are replaced:
 - For IRs by the Article 14 (BR 216/2008) procedure. *
 - For AMCs by the alternative means of compliance procedure.



*Article 14 Flexibility provisions

14.1 Immediate reaction to a safety problem

14.4 Unforeseen urgent operational circumstances or operational need of a limited duration

MS shall notify the Agency, the Commission and the other MS.
Assessment by the Agency within one month.

14.6 Other means to attain an equivalent level of protection

MS shall notify the Agency and the Commission of their intent.
Assessment by the Agency within two months.

- ▶ **For transposing EU-OPS and JAR-OPS 3 (cont.)**
 - ▶ Rules requiring an approval are either
 - » transposed as IR, or
 - » if transposed as AMC have been removed (alternative MOC procedure).
 - ▶ Rules which are already covered in the essential requirements (ER) of the BR have been retained with link to the ER.

- **For transposing EU-OPS and JAR-OPS 3 (cont.)**
 - Rules containing **"*acceptable to the authority*"** have been transposed as **"*the operator shall specify in the OM*"**
 - Rules containing **"*if approved by the authority*"** have been transposed as an item requiring prior approval, or being included in the AOC.
 - GM3 ORO.GEN.130(b) Changes



Transposition of EU-OPS

EU-OPS	Part-CAT	Part-SPA	Part-ORO	Part-ARO	Annex 1	Others
SUBPART A — Applicability and definitions					DEF	CR OPS
SUBPART B — General	GEN		GEN/AOC/MLR		DEF	
SUBPART C — Operator certification and supervision			GEN/AOC	GEN/OPS		
SUBPART D — Operational procedures	OP	MNPS/PBN /ETOPS/ RVSM	GEN/MLR	OPS	DEF	SERA AMC-20
SUBPART E — All weather operations	OP	LVO		OPS	DEF	SERA
SUBPART F — Performance general	POL.A				DEF	
SUBPART G — Performance Class A	POL.A					
SUBPART H — Performance Class B	POL.A					
SUBPART I — Performance Class C	POL.A					
SUBPART J — Mass and balance	POL.MAB				DEF	Part-M



Transposition of EU-OPS

EU-OPS	Part-CAT	Part-SPA	Part-ORO	Part-ARO	Annex 1	Others
SUBPART K — Instruments and equipment	IDE.A.					Part-M AMC-20
SUBPART L — Communication and navigation equipment	IDE.A.					Part-M AMC-20
SUBPART M — Aeroplane maintenance						Part-M
SUBPART N — Flight crew			FC		DEF	Part-FCL
SUBPART O — Cabin crew			CC	AR.CC		Part-CC
SUBPART P — Manuals, logs and records	OP		GEN/MLR			
SUBPART Q — Flight and duty time limitations and rest requirements			FTL		DEF	OPS.055
SUBPART R — Transport of dangerous goods by air	GEN	DG		OPS	DEF	
SUBPART S — Security	GEN		SEC			



Transposition of JAR-OPS 3

JAR-OPS 3	Part-CAT	Part-SPA	Part-ORO	Part-ARO	Annex 1	Others
SUBPART A — Applicability and definitions					DEF	CR OPS
SUBPART B — General	GEN	NVIS/HHO/ HEMS	GEN/AOC/ MLR		DEF	
SUBPART C — Operator certification and supervision			GEN/AOC	GEN/OPS		
SUBPART D — Operational procedures	OP	PBN	GEN/MLR	OPS	DEF	SERA AMC-20
SUBPART E — All weather operations	OP	LVO		OPS	DEF	SERA
SUBPART F — Performance general	POL.H				DEF	
SUBPART G — Performance Class 1	POL.H					
SUBPART H — Performance Class 2	POL.H					
SUBPART I — Performance Class 3	POL.H					
SUBPART J — Mass and balance	POL.MAB				DEF	



Transposition of JAR-OPS 3

JAR-OPS 3	Part-CAT	Part-SPA	Part-ORO	Part-ARO	Annex 1	Others
SUBPART K — Instruments and equipment	IDE.H.					
SUBPART L — Communication and navigation equipment	IDE.H.					
SUBPART M — Helicopter maintenance						Part-M
SUBPART N — Flight crew			FC		DEF	Part-FCL
SUBPART O — Crew members other than flight crew			TC			
SUBPART P — Manuals, logs and records	OP		GEN/MLR			
SUBPART Q — Flight and duty time limitations and rest requirements			FTL		DEF	
SUBPART R — Transport of dangerous goods by air	GEN	DG		OPS	DEF	
SUBPART S — Security	GEN		SEC			



Cross reference table

Cross reference tables:

- Comparison EASA OPS with JAR-OPS 3 and EU-OPS
- Difference statements
- Status: version 02 was published before end of 2012
- http://easa.europa.eu/flightstandards/doc/Cross%20reference%20table_version02.xlsx

Sec. #	European rule IR/AMC/GM	European rule reference	European rule title	EU-OPS/JAR-OPS3 IR/ACJ/AMC/IEM	EU-OPS rule reference	JAR-OPS3 rule reference	EU-OPS/JAR-OPS3 rule title	Difference to EU-OPS Classification	Difference to EU-OPS Description	Difference to JAR-OPS3 Classification	Difference to JAR-OPS3 Description
1	IR	Annex I	Definitions for terms used in Annexes II to VII	IR	-	3.005(f) - Appendix 1, (a)(1)	Operations for small helicopters (VFR day only)	-	-	Amended	The definition in EASA OPS is more specific. Small helicopters (as defined in JAR-OPS 1) are treated as non-complex helicopters (in the sense of the Basic Regulation).
1	IR	Annex I	Definitions for terms used in Annexes II to VII	IR	1.037(a)4.	-	Accident prevention and flight safety programme	No change	Definition for 'flight data monitoring' extracted from EU-OPS rule	-	-
1	IR	Annex I	Definitions for terms used in Annexes II to VII	IR	1.1150(a)1, 4 - 6, 15	3.1150(a)(1), (3), (4), (15)	Terminology	No change	-	No change	-
1	IR	Annex I	Definitions for terms used in Annexes II to VII	IR	1.165(a)	3.165(a)	Leasing	Amended	The terms are aligned with Art. 2 of Reg. (EC) No 1008/2008	Amended	The terms are aligned with Art. 2 of Reg. (EC) No 1008/2008
1	IR	Annex I	Definitions for terms used in Annexes II to VII	ACJ	1.345 2.a, 2.g, 2.k	-	Ice and other contaminants	Amended	Anti-icing' and 'de-icing' refer to aircraft, not only aeroplanes. 'Hold-over time' aligns with ICAO Doc 9640, 2nd ed..	New	Definitions from EU-OPS refer to aircraft, not aeroplanes and therefore apply to helicopters too.
1	IR	Annex I	Definitions for terms used in Annexes II to VII	IR	1.430 - Appendix 1 (f)1.(i), (ii)	3.430 - Appendix 1, (d)(1)	Precision approach — Category II and other than Standard Category II operations	No change	-	Amended	The scope of OTS CAT II has been extended to helicopter operations.
1	IR	Annex I	Definitions for terms used in Annexes II to VII	IR	1.430 - Appendix 1 (New), (b)(3)	-	Aerodrome operating minima	Amended	Approach procedure with vertical guidance': does not provide for the authority to approve lower minima [Placed in main Annex I with Opinion 1/2012]	-	-
1	IR	Annex I	Definitions for terms used in Annexes II to VII	IR	1.430 - Appendix 1 (New), (b)(1)	-	Aerodrome operating minima	Amended	CAT I approach operation': GNSS using SBAS is included	-	-



EUROPEAN AVIATION SAFETY AGENCY
AGENCE EUROPÉENNE DE LA SÉCURITÉ AÉRIENNE
EUROPÄISCHE AGENTUR FÜR FLUGSICHERHEIT

10TH
ANNIVERSARY

Regulation No 965/2012

‘Air operations’

- Cover Regulation
- Overview of annexes

Your safety is our mission.
easa.europa.eu



Cover regulations

The Cover regulation is the actual rule. It is followed by annexes and consists of at least the following:

Applicability of the rule.

Entry into force.

Transition measures.



“Cover Regulation” Air operations

- Article 1 Subject matter and scope
- Article 2 Definitions
- Article 3 Oversight capabilities
- Article 4 Ramp inspections
- Article 5 Air operations
- Article 6 Derogations
- Article 7 Air operator certificates
- Article 8 Flight time limitations
- Article 9 Minimum equipment lists
- Article 10 Entry into force



“Cover Regulation” Air operations

➤ **Scope (Art. 1) (OPS Phase I)**

- CAT operations with
 - aeroplanes, helicopters

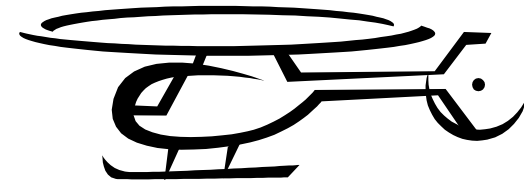

➤ Excluded for the time being are:

- operations with airships, tilt-rotor aircraft, tethered balloons and remotely piloted aircraft
- operations by design or production organisations related to the introduction or modification of aircraft types
- A-to-A operations with performance class B aeroplanes and non-complex helicopters



“Cover Regulation” Air operations

- **Definitions (Art. 2) : CAT & commercial operation**
 - Commercial air transport (CAT) operation (Reg. 965/2008)
 - Aircraft operation to transport passengers, cargo or mail for remuneration or other valuable consideration.
 - Commercial operation (Basic Regulation 216/2008)
 - Any operation of an aircraft, in return for remuneration or other valuable consideration, which is available to the public or, when not made available to the public, which is performed under a contract between an operator and a **customer**, where the **latter** has **no control over the operator**.



“Cover Regulation” Air operations

➤ **Oversight capabilities (Art. 3) :**

- Member State can designate more than one entity as competent authority provided that :
 - areas of competence, responsibility and geographic limitations are clearly defined
 - Co-ordination between entities ensures effective oversight
- Authority to have necessary capability to ensure the oversight of all persons and organisations, including sufficient resources
- Avoidance of conflict of interest
- Lists the tasks that authority personnel is empowered to perform



“Cover Regulation” Air operations

➤ **Ramp inspections (Art. 4) :**

- Ramp inspection shall be carried out in accordance with Subpart RAMP of Annex 2 (Part-ARO)

➤ **Air operations (art. 5) :**

- Annexes III (Part-ORO) and IV (part-CAT) applicable to CAT operators
- Annex V (Part-SPA) applicable to CAT operators depending on the type of operations

➤ **Derogations (Art. 6)**

- CAT AtoA with Perf. B aeroplanes => EU-OPS
- CAT AtoA non-complex helicopters => National rules
- Specific Annex II aircraft when used in CAT operations.
- Member States may continue to require a specific approval and additional requirements for helicopter offshore operations.
- Single engine IMC operations with aeroplanes may continue to be operated in accordance with the conditions contained in exemptions accepted under EU-OPS.
- Helicopter operations to public interest sites may continue outside performance class 1 and under conditions defined by the MS.



“Cover Regulation” Air operations

- **Air Operator certificates (Art. 7):**
 - Conversion of AOC
- **Flight time limitation (Art. 8):**
 - Applicable requirements:
 - Aeroplane: EU-OPS subpart Q
 - Helicopters: National rules
- **Minimum equipment list (Art. 9):**
 - EU-OPS approved MEL are deemed to be approved in accordance with Regulation No 965/2012.
- **Entry into force (art. 10):**
 - Entry into force and transition



Annex I: Definitions

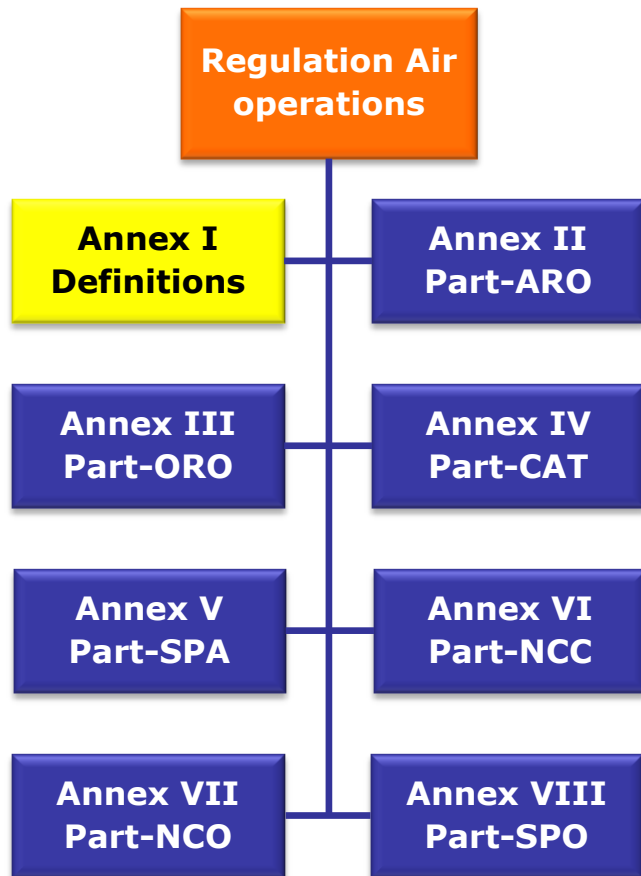

Applicability:

- » operators and
- » competent authorities



Annex II: Part-ARO

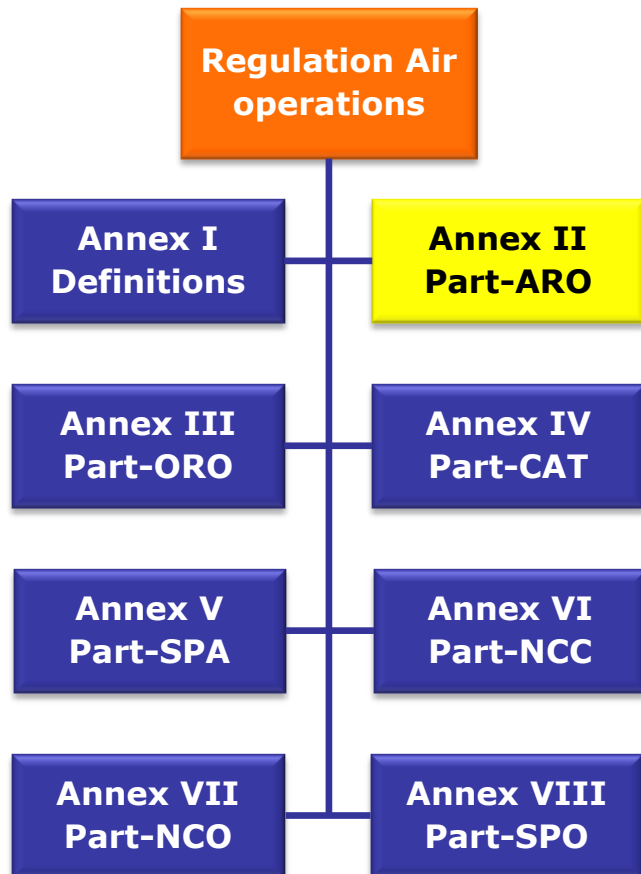

Applicability:

- Authority requirements for air operations for National aviation authorities



Annex II: Part-ARO

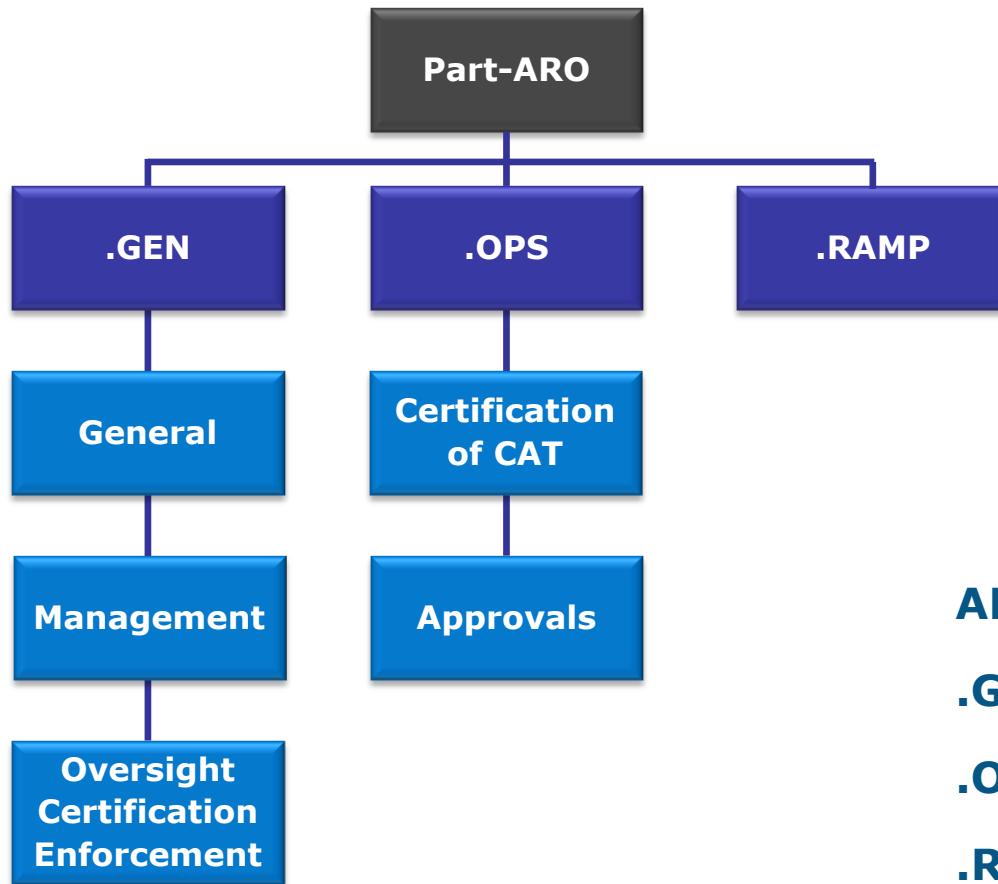

ARO – Authority requirements

.GEN General requirements

.OPS Air operations

.RAMP Ramp inspections



ARO requirements

▪ **ARO.GEN**

General

- AltMOC process (ORO.GEN.120)

Management

- Management system / Changes to MS
- Qualified entities

Oversight

- Oversight process / Programme
- Operator notified changes
- Findings / Corrective actions

▪ **ARO.OPS**

CAT

- Lease agreement

Approvals

- Specific approvals

▪ **ARO.RAMP**

- Prioritisation criteria
- Training
- Procedure



Annex III: Part-ORO

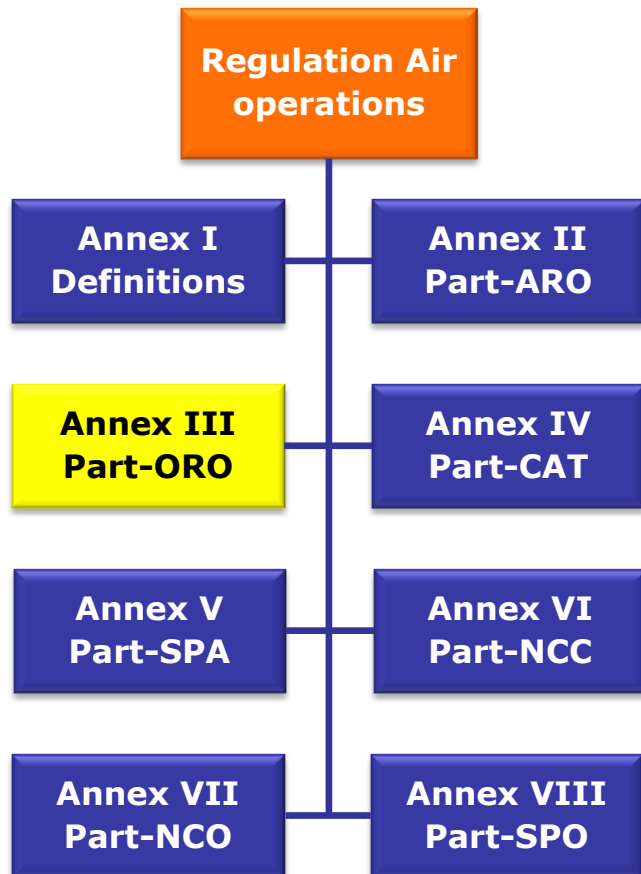

Applicability:

- » Organisation requirements for;
 - » CAT operators
 - » NCC operators
 - » SPO operators
 - » Commercial operations
 - » Non-commercial operations with complex aircraft



Annex III: Part-ORO

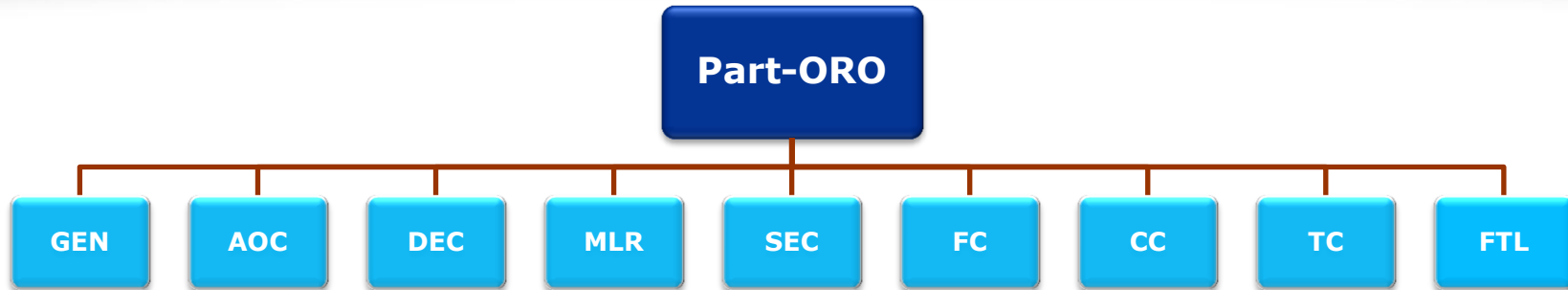

.GEN – general requirements

.AOC – air operator certification

.DEC – declaration (added soon)

.MLR – manual, logs, records

.SEC – security

.FC – flight crew

.CC – cabin crew

.TC – technical crew

.FTL – flight time limitations
(added soon)



ORO.GEN – General requirements

Part-ORO		
.GEN	ORO.GEN.105	<u>Competent authority</u> <ul style="list-style-type: none"> ▪ Definition of principle place of business as Reg. (EC) No 1008/2008
.AOC		
.DEC		
.MLR	ORO.GEN.130	<u>Changes to organisations</u> <ul style="list-style-type: none"> ▪ Prior approval for some major changes, see GM in ORO.GEN, e.g. changes to management system ▪ Minor changes: procedure agreed with competent authority
.SEC		
.FC		
.CC	ORO.GEN.200	<u>Management system</u> <ul style="list-style-type: none"> ▪ Implements ICAO standards on safety management systems (SMS) ▪ Lists the elements that the organisations must address. ▪ Safety concern for all personnel
.TC		
.FTL		



ORO.AOC – Air Operator certification

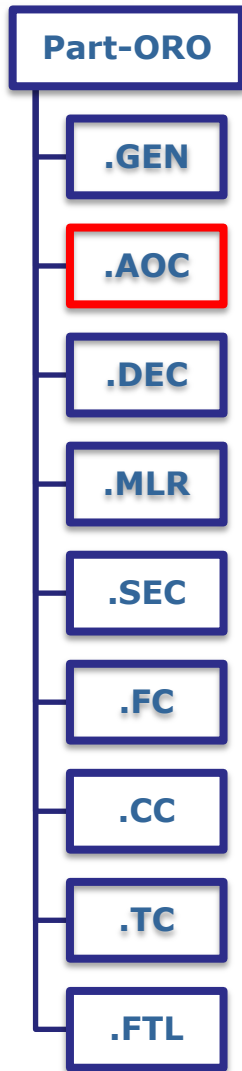

ORO.AOC.100	<u>Application for an AOC</u>
ORO.AOC.105	<u>OPS SPECS and privileges of an AOC holder</u>
ORO.AOC.110	<u>Leasing</u>
ORO.AOC.115	<u>Code-share</u>
ORO.AOC.120	Approvals to provide cabin crew training and to issue cabin crew attestations
ORO.AOC.125	Non-commercial operations of aircraft listed in the operations specifications by the holder of an AOC
ORO.AOC.130	Flight Data Monitoring - aeroplanes
ORO.AOC.135	Personnel requirements
ORO.AOC.140	Facility requirements
ORO.AOC.150	Documentation requirements



ORO.AOC - Leasing

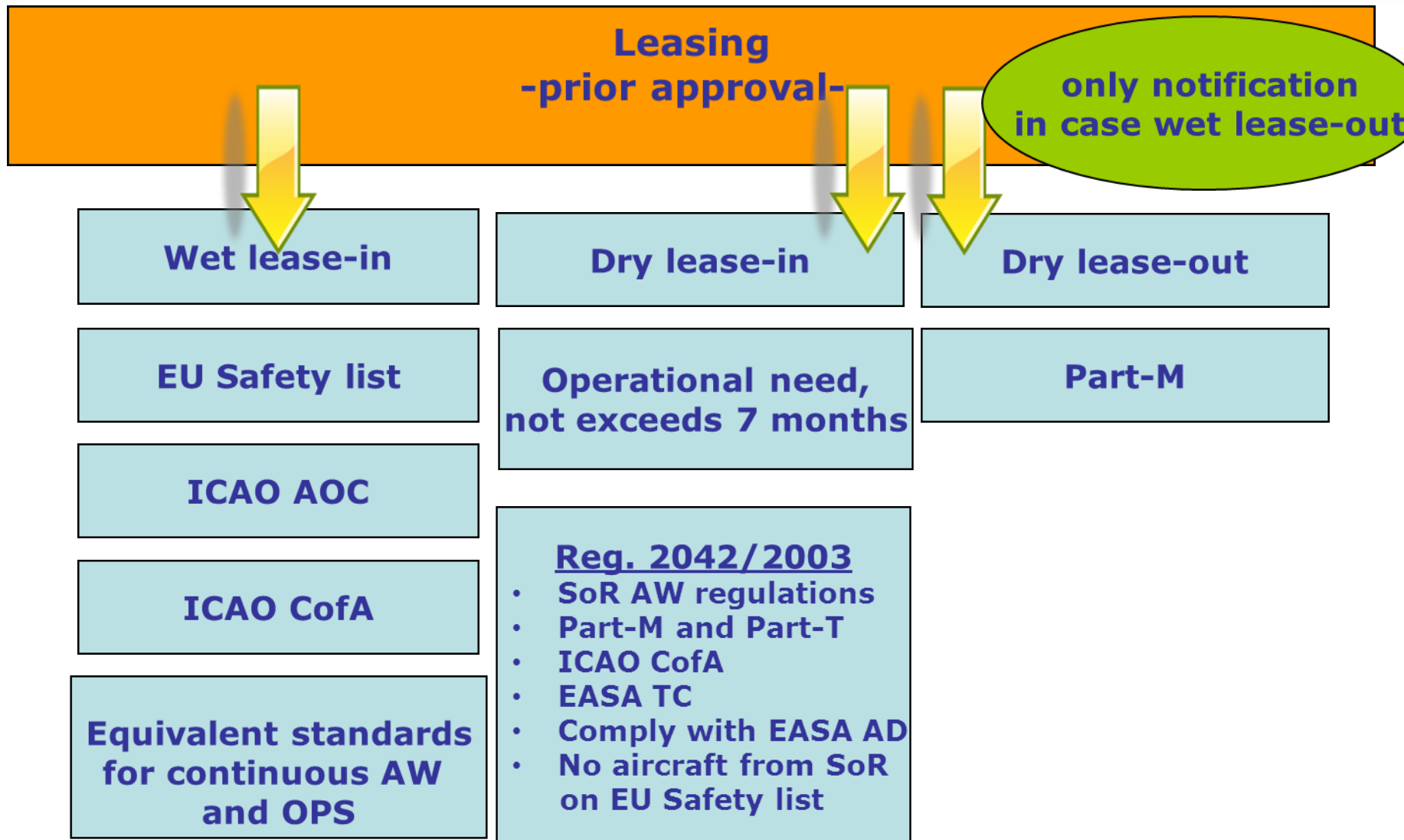



Non-commercial operations of aircraft listed in the operations specifications by the holder of an AOC

- » No declaration is needed
- » Identification of:
 - » the applicable requirements
 - » differences between operating procedures when used in commercial and non-commercial operations
- » Ensure that personnel are familiar with procedures
- » Prior approval



ORO.MLR - Manuals, Logs and Records

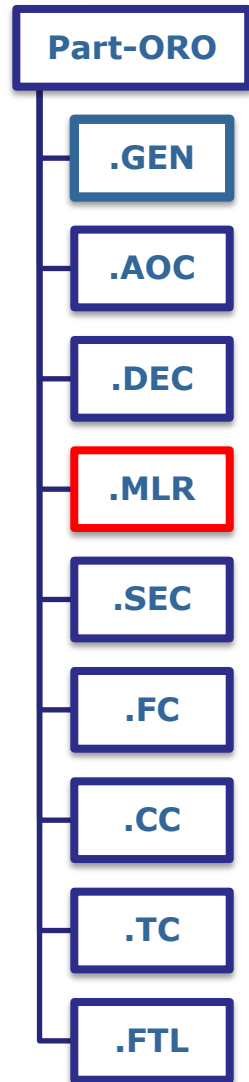

ORO.MLR.100	<u>Operations Manual- general</u> <ul style="list-style-type: none">Up to date & inform relevant personnel on changes to manual
ORO.MLR.101	<u>Structure of Manual for CAT</u> <ul style="list-style-type: none">Part A, B, C & D
ORO.MLR.105	<u>Minimum Equipment List</u> <ul style="list-style-type: none">Approved by competent authorityMEL based on MMEL resulting from the OSD
ORO.MLR.110	<u>Journey log</u>
ORO.MLR.115	<u>Record Keeping</u> <ul style="list-style-type: none">Management System information 5 yrsOperational information 3 yrs

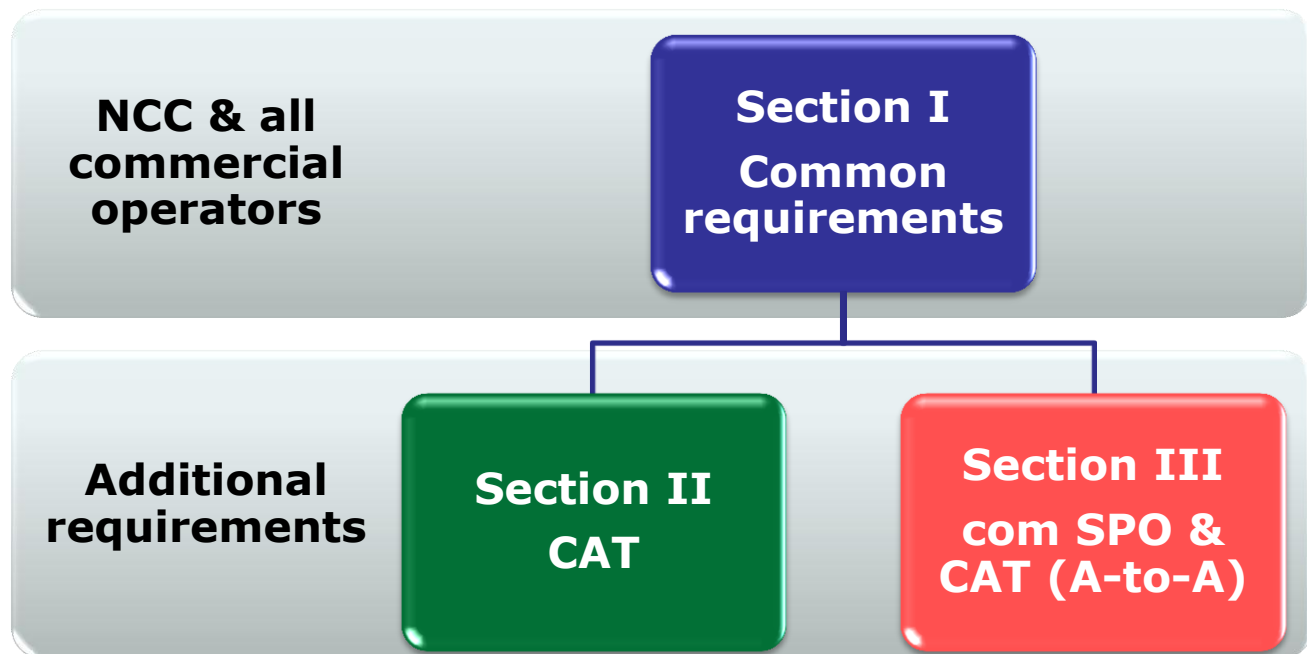
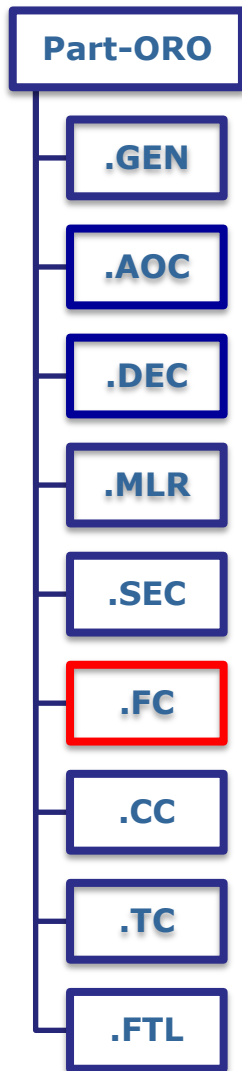



➤ Highlights

- CRM training for single pilot operations now mandatory (ORO.FC.115)
- Integration of Operational Suitability Data (OSD) (ORO.FC.145)
 - for operators to account for OSD standards and recommendations when developing their training programmes
- FSTD “user approval” for commercial operators:
 - FSTD shall replicate the aircraft, as far as possible
 - management of differences between FSTD and aircraft
 - management of changes to the FSTD

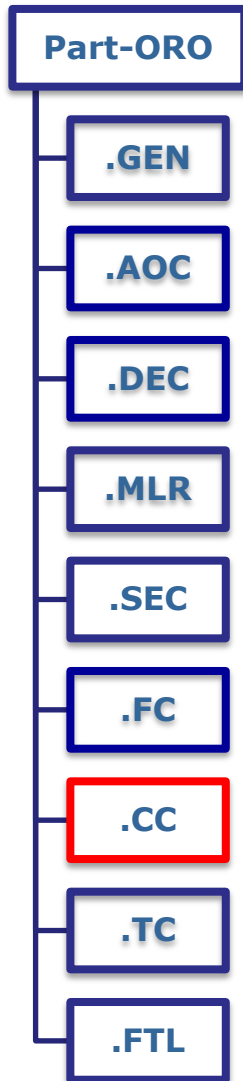

- Contains conversion and recurrent training
- Reference to Aircrew Regulation (290/2012) for initial training
- Integration of Operational Suitability Data (OSD) (ORO.CC.125)



ORO.TC – Technical Crew

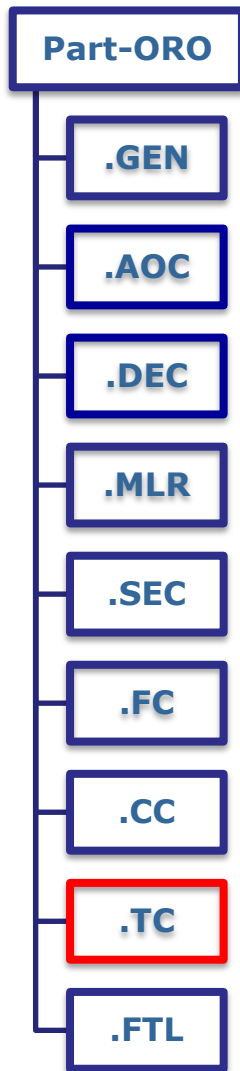

- .GEN** – general requirements
- .AOC** – air operator certification
- .DEC** – declaration
- .MLR** – manual, logs, records
- .SEC** – security
- .FC** – flight crew
- .CC** – cabin crew
- .TC** – technical crew
- .FTL** – flight time limitations



➤ **Applicability:**

- technical crew members in commercial air transport HEMS, HHO, NVIS operations
- further experience and training requirements for HEMS, HHO and NVIS operations are contained in the specific Part-SPA subparts
- aerial work task specialists are included in Part-SPO

➤ **Main change compared to JAR-OPS 3: no limitation on number of types in IR anymore**

- operator to specify the maximum number of aircraft types in the OM, taking into account the specific operating environment, equipment, procedures



Annex IV: Part-CAT

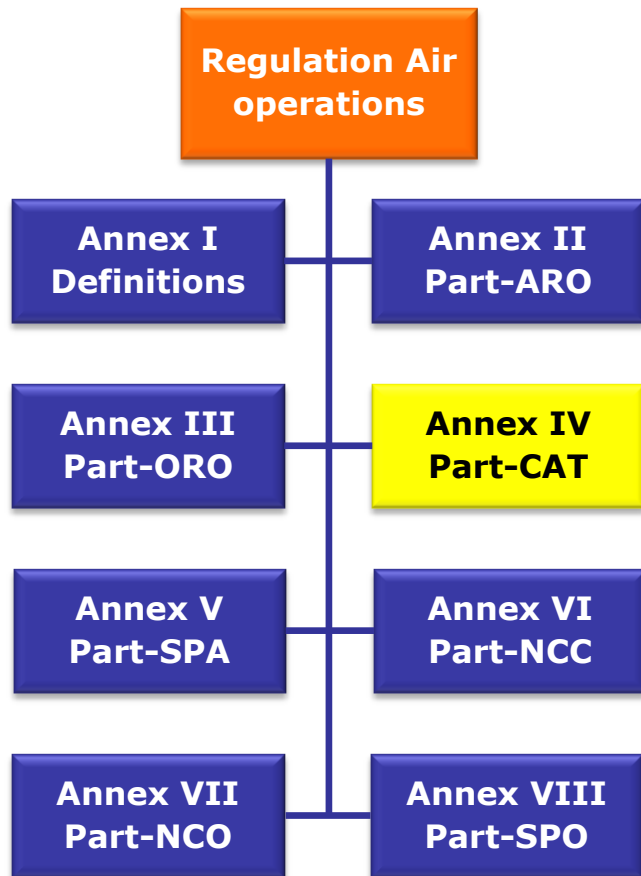

Applicability:

- » Technical rules for CAT operations with;
 - » Complex aircraft:
A, H
 - » Non-complex aircraft:
A, H (S, B added soon)
 - » A-to-A operations with A, H
(added soon)



Annex IV: Part-CAT

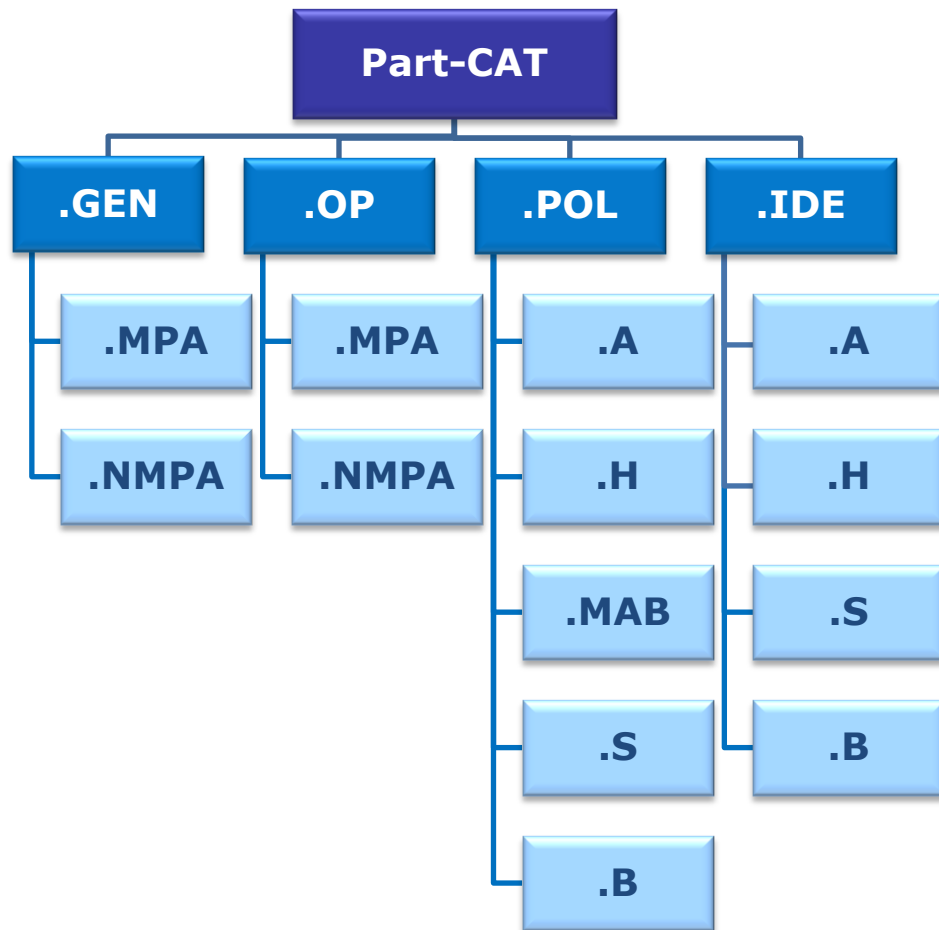

CAT – commercial air transport

.GEN – general requirements

.OP – operational procedures

.POL – performance and operating limitations

.IDE – instruments, data, equipment

.MPA – motor-powered aircraft

.NMPA – non-motor-powered aircraft

.A, .H, .S, .B - aeroplanes, helicopters, sailplanes, balloons

.MAB – mass and balance



Annex IV: Part-CAT

➤ Key points

- Part contains technical rules for all CAT operations.
- Part structured into aircraft-specific sections/chapters.
- Part could be easily amended for other aircraft categories, e.g. tilt rotor aircraft, airships, remotely piloted aircraft systems.
- Rule text aligned with the content of;
 - EU-OPS and Section 1 of JAR-OPS 3,
 - section 2 material of JAR-OPS 1 and JAR-OPS 3.
- Improved balance between Implementing Rules and AMC/GM.
- EU-OPS/JAR-OPS 3 text has been given precedence over ICAO SARPs.



Introduced changes:

- CAT.GEN.MPA.100 Crew responsibilities
- CAT.IDE.A.195 Data link recording
- CAT.POL.H.420 Helicopter operations over a hostile environment located outside a congested area



Annex V: Part-SPA

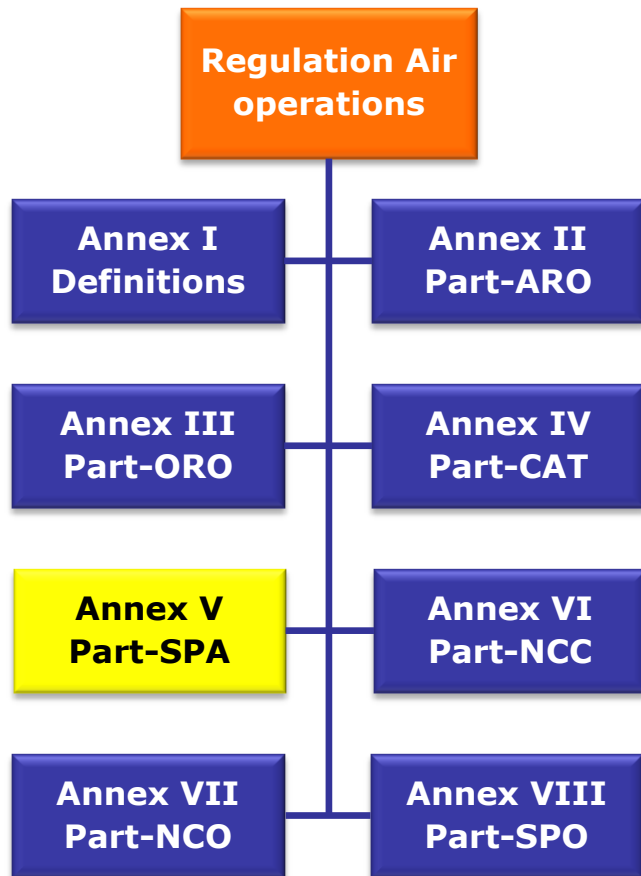

Applicability:

- Operators which wish to conduct an operation requiring a specific approval.
- To be documented in;
 - OPSPECS for certified operators,
 - list of specific approvals for non-certified operators.



Annex V: Part-SPA

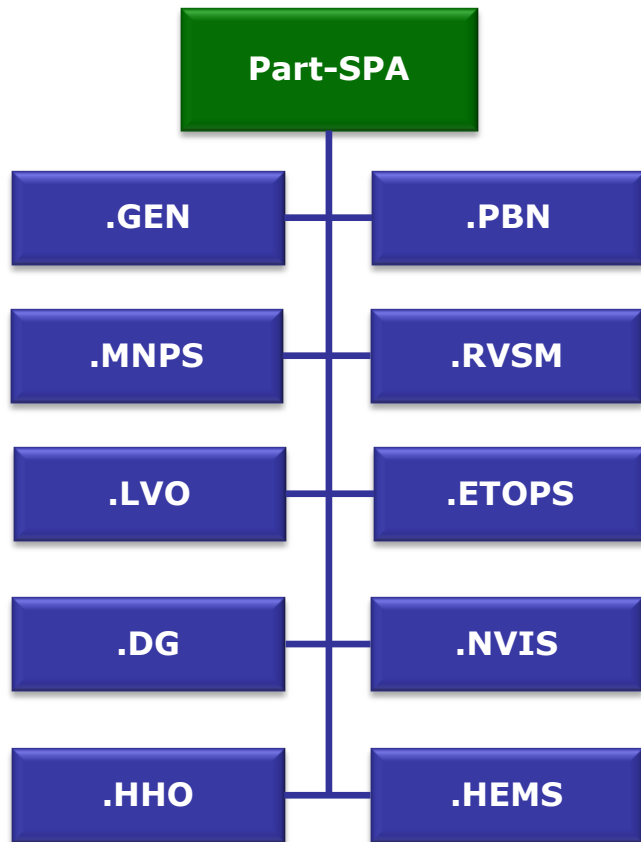

- **.GEN** – general requirements.
- **.PBN** – performance based navigation
- **.MNPS** – minimum navigation performance specifications.
- **.RVSM** – reduced vertical separation minima.
- **.LVO** – low visibility operations.
- **.ETOPS** – extended range operations with two-engined aeroplanes.
- **.DG** – dangerous goods.
- **.NVIS** – night vision imaging systems.
- **.HHO** – helicopter hoist operations.
- **.HEMS** – helicopter emergency medical services.



Annex V: Part-SPA

SPA.GEN.100 Competent authority

For commercial operations;

- » operator's principal place of business.

For non-commercial operations;

- » place where the operator is established or residing,
- » when using an aircraft registered in a third country, the approvals for PBN, MNSP, RVSM may be issued by the third country State of Registry.



SPA.GEN.110

- ▶ **Documentation of specific approvals**
 - » for commercial operations in the “operations specifications” (OPSPECS)
 - » for non-commercial operations in the “list of specific approvals”

- ▶ **The corresponding authority requirements are specified in Part-ARO including the forms for**
 - » OPSPECS and
 - » list of specific approvals



Annex VI: Part-NCC

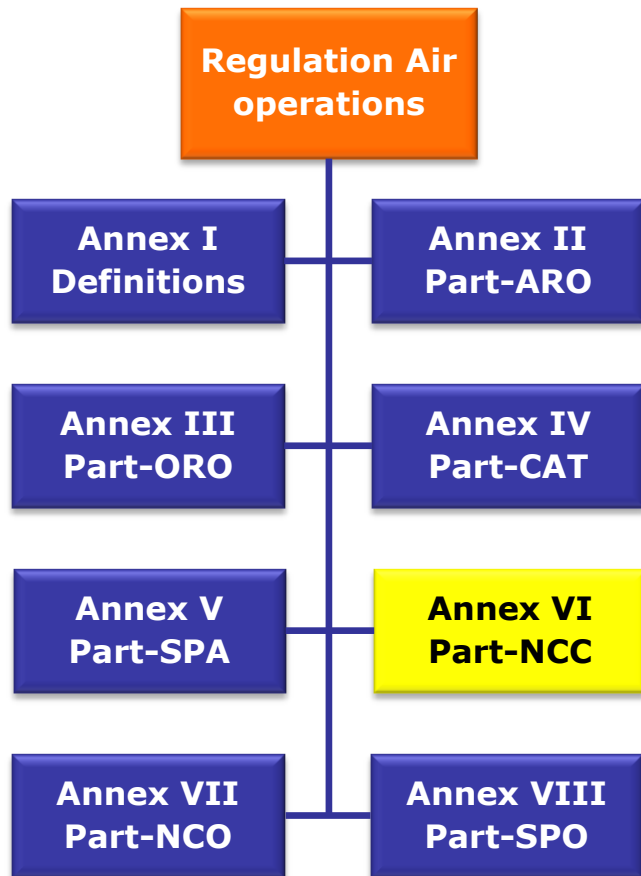

Applicability:

- Technical rules for non-commercial operations of complex motor-powered aircraft;
 - complex aeroplanes,
 - complex helicopters.



Annex VI: Part-NCC

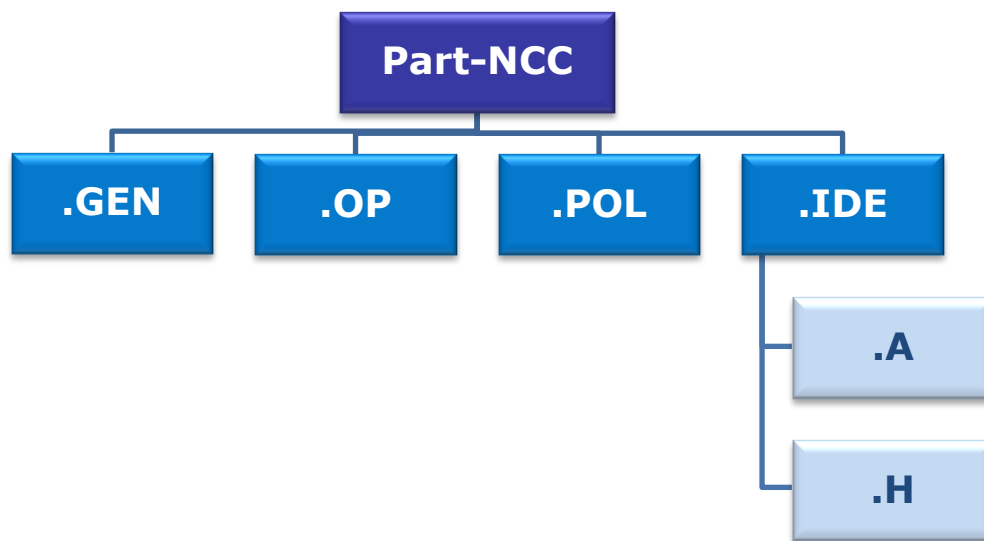

NCC – non-commercial operations with complex motor-powered aircraft

.GEN – general requirements

.OP – operational procedures

.POL – performance and operating limitations

.IDE – instruments, data, equipment

.A - aeroplanes

.H - helicopters



Annex VI: Part-NCO

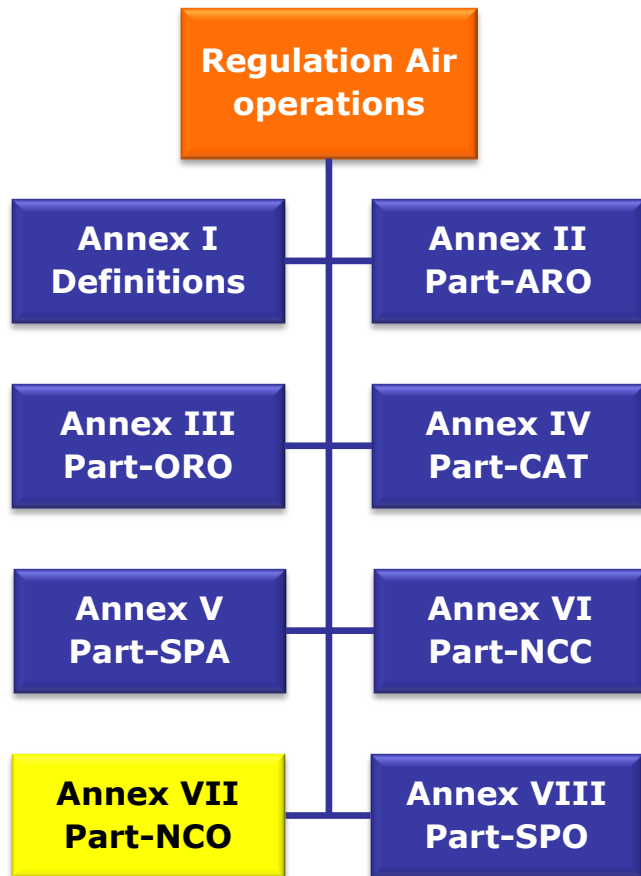

Applicability:

- » Technical rules for non-commercial operations of other-than-complex motor-powered aircraft:
 - » Non-complex aeroplanes
 - » Non-complex helicopters
 - » Sailplanes
 - » Balloons



Annex VII: Part-NCO

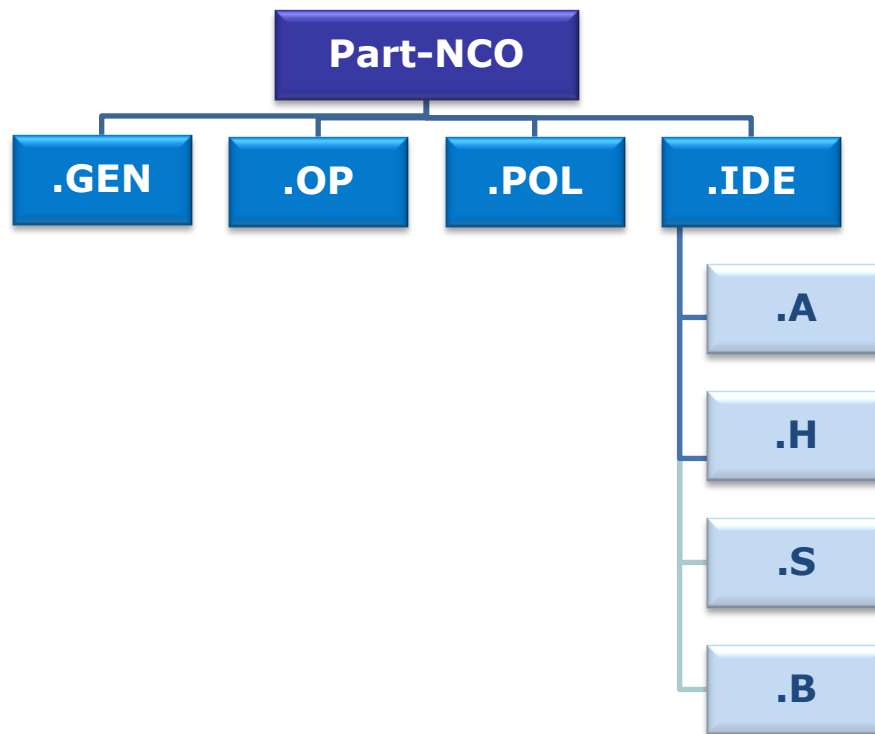

NCO – non-commercial operations with other-than-complex motor-powered aircraft

.GEN – general requirements

.OP – operational procedures

.POL – performance and operating limitations

.IDE – instruments, data, equipment

.A, .H, .S, .B - aeroplanes, helicopters, sailplanes, balloons



Annex VIII: Part-SPO

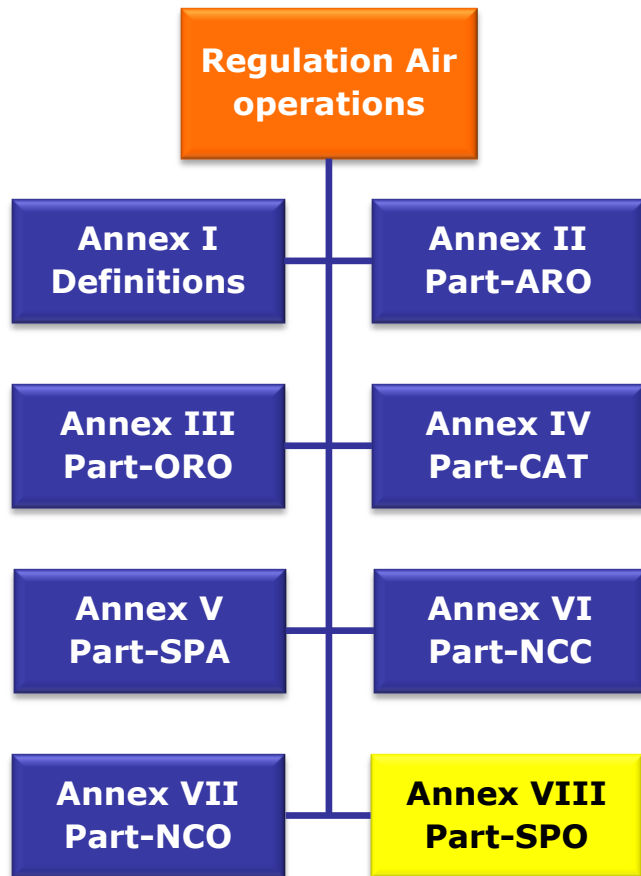

Applicability:

- Technical rules for commercial and non-commercial specialised operations, e.g. aerial work:
 - Aeroplanes
 - Helicopters
 - Sailplanes
 - Balloons



Annex VIII: Part-SPO

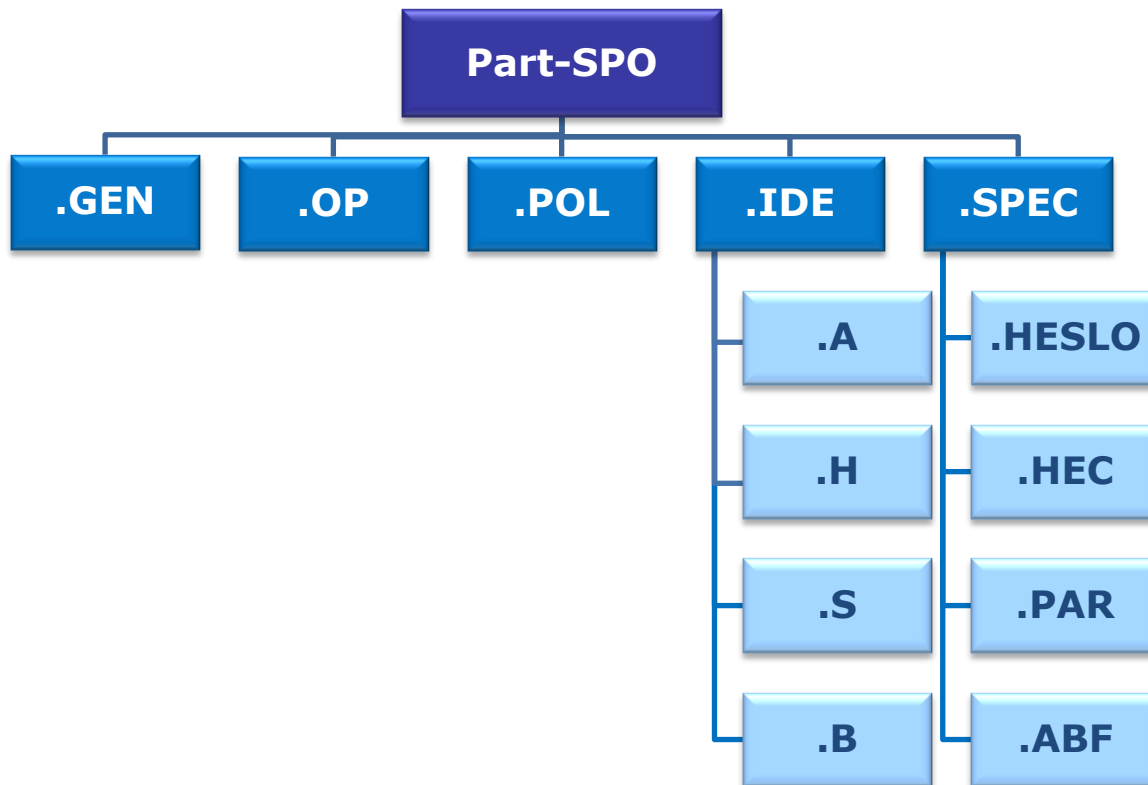

SPO – specialised operations – commercial and non-commercial, all type of aircraft

.SPEC – specific requirements

.HESLO – helicopter external sling load operations

.HEC – human external cargo operations

.PAR – parachute operations

.ABF – aerobatic flights



EUROPEAN AVIATION SAFETY AGENCY
AGENCE EUROPÉENNE DE LA SÉCURITÉ AÉRIENNE
EUROPÄISCHE AGENTUR FÜR FLUGSICHERHEIT

10TH
ANNIVERSARY

Any Questions?

Your safety is our mission.
easa.europa.eu



EUROPEAN AVIATION SAFETY AGENCY
AGENCE EUROPÉENNE DE LA SÉCURITÉ AÉRIENNE
EUROPÄISCHE AGENTUR FÜR FLUGSICHERHEIT

Flight Time Limitations

Opinion 04/2012 on flight and duty time limitations and rest requirements (FTL) for commercial air transport (CAT) with aeroplanes and other FTL rulemaking tasks

Your safety is our mission.
easa.europa.eu



"My mind clicks on and off...I try letting one eyelid close at a time while I prop the other open with my will. But the effort's too much. Sleep is winning. My whole body argues dully that nothing, nothing life can attain, is quite so desirable as sleep."

– Charles Lindbergh, describing the fatigue that struck him nine hours into his 33-hour solo Atlantic crossing.



From intuition to science

**Scientific
concept**

**Subjective
experience**

**Everybody
has the
feeling to be
an expert**

**Perception
influences
behaviour**

Fatigue

**Linked to
physiological
mechanisms**

**Perception of fatigue
linked to psychological,
social, cultural factors**



Alertness components

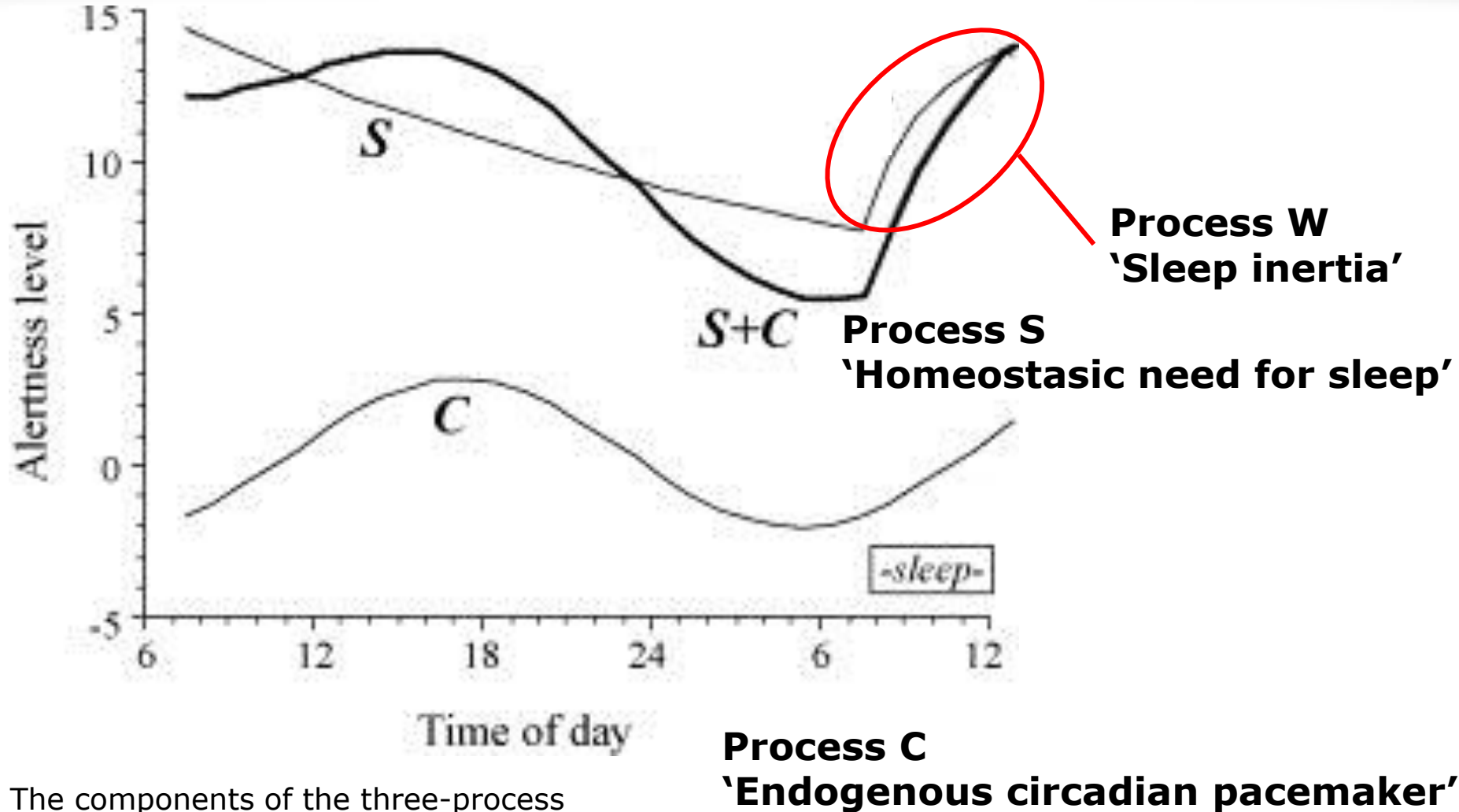

The components of the three-process Model of alertness, adapted from Åkerstedt et al, 2008



Fatigue is a biological drive for recuperative rest

Time of Day

Fatigue

Time awake

Task related factors

Rest

"Sleepiness"

"Sleep"

**Reduced
Performance
Capability**

Accident



Fatigue Factors

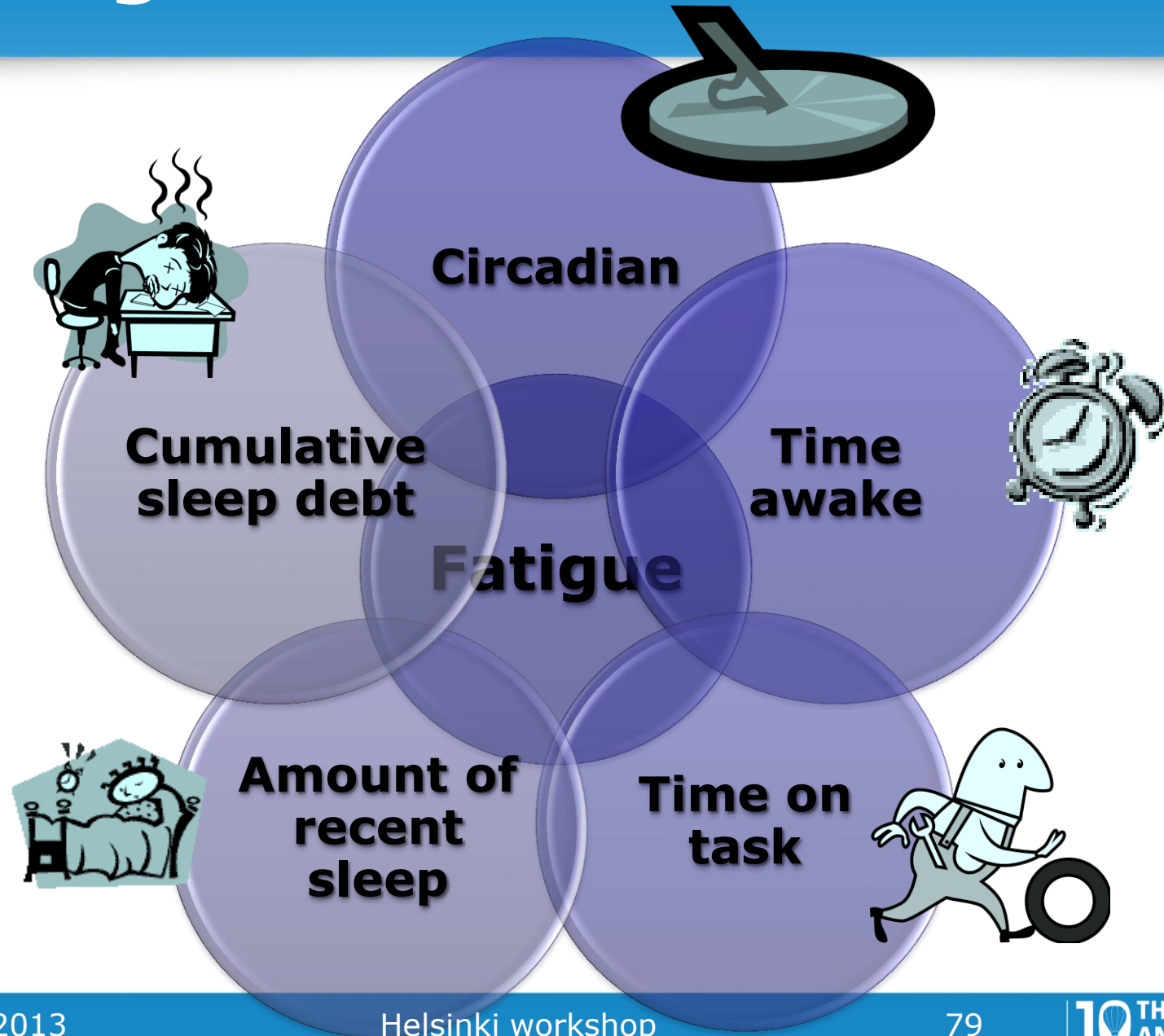



FTL – Background

Present

Regulation 1899/2006 (EU-OPS)

- **Recital 7: Non-regression clause**
- **Recital 11: MS may apply more stringent FTL**
- **Art. 8(4): Areas not covered by Subpart Q**

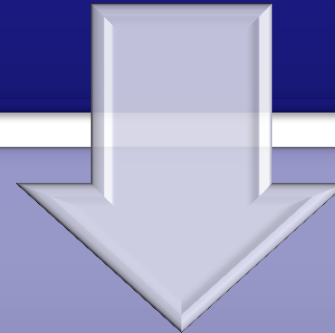

Regulation 216/2008 (Basic Regulation) Art. 22(2):

- **EASA shall issue CS and IR including substantive Subpart Q provisions**

Future



FTL – Article 8(4) Provisions

OPS 1.1105 point 6 – extended FDP (**split duty**);

OPS 1.1110 point 1.3 rest compensating **time zone differences**;

OPS 1.1110 point 1.4.1 –**reduced rest** arrangements;

OPS 1.1115 – extension of flight duty period due to **in-flight rest**; and

OPS 1.1125 point 2.1 – other forms of **standby**.



FTL – Rule Structure

**Core FTL
elements in
IR, based on
Subpart Q**

**Art. 8
provisions in
CS, based on
MS & industry
best practices**



FTL – Flexibility Art. 22(2)

**MS to notify
EASA, CION,
other MS**

**Individual flight time
specification scheme**

**EASA
assessment
based on
scientific and
medical
evaluation**

Panel of experts

**Contents of
individual
schemes shall
be published**



Science in FTL



...regulations shall be based upon scientific principles and knowledge,...



...rules based on scientific knowledge and best practices...



...taking into account the latest scientific and technical evidence...



FTL - Structure

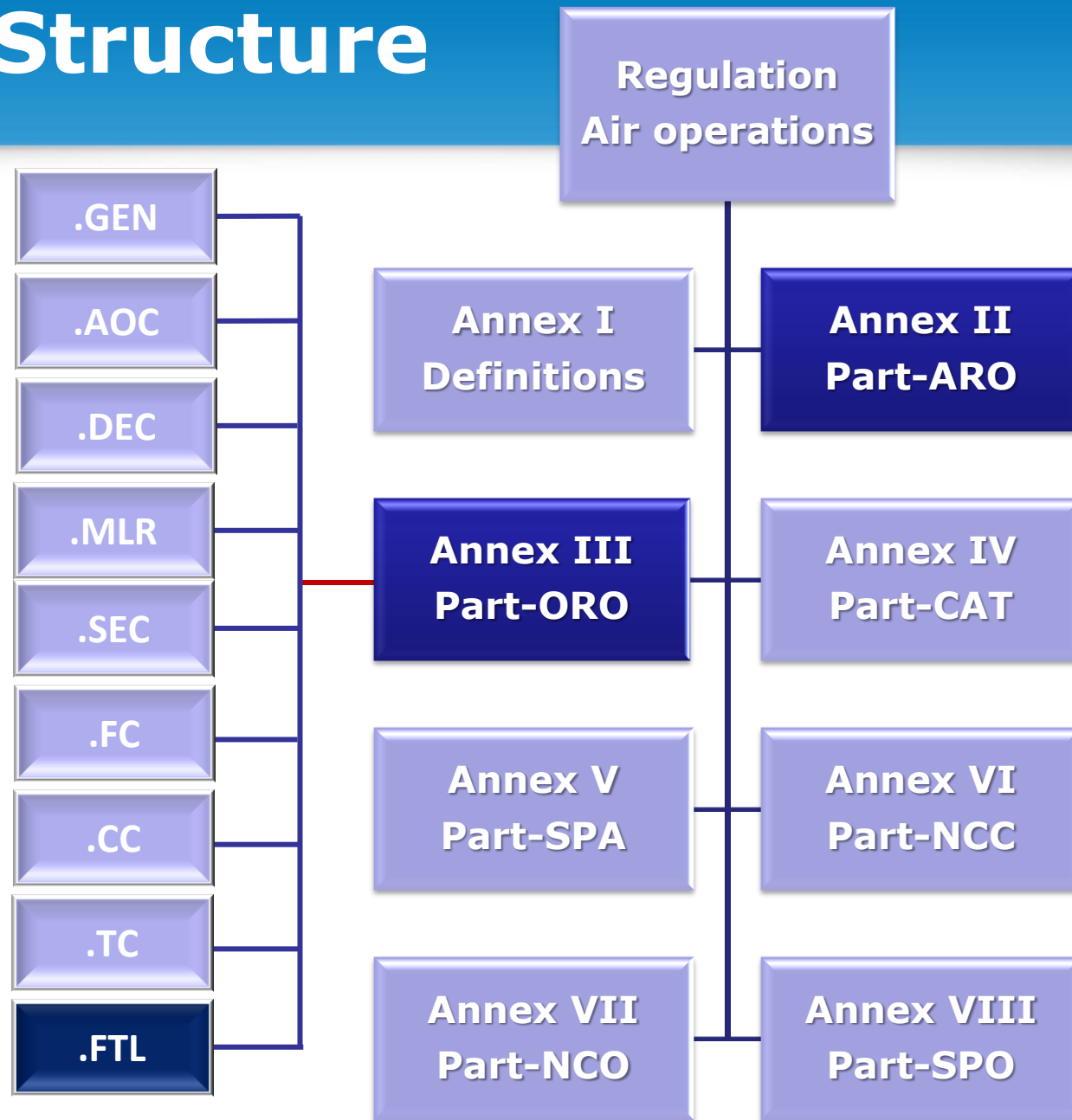

Link with other FTL Tasks

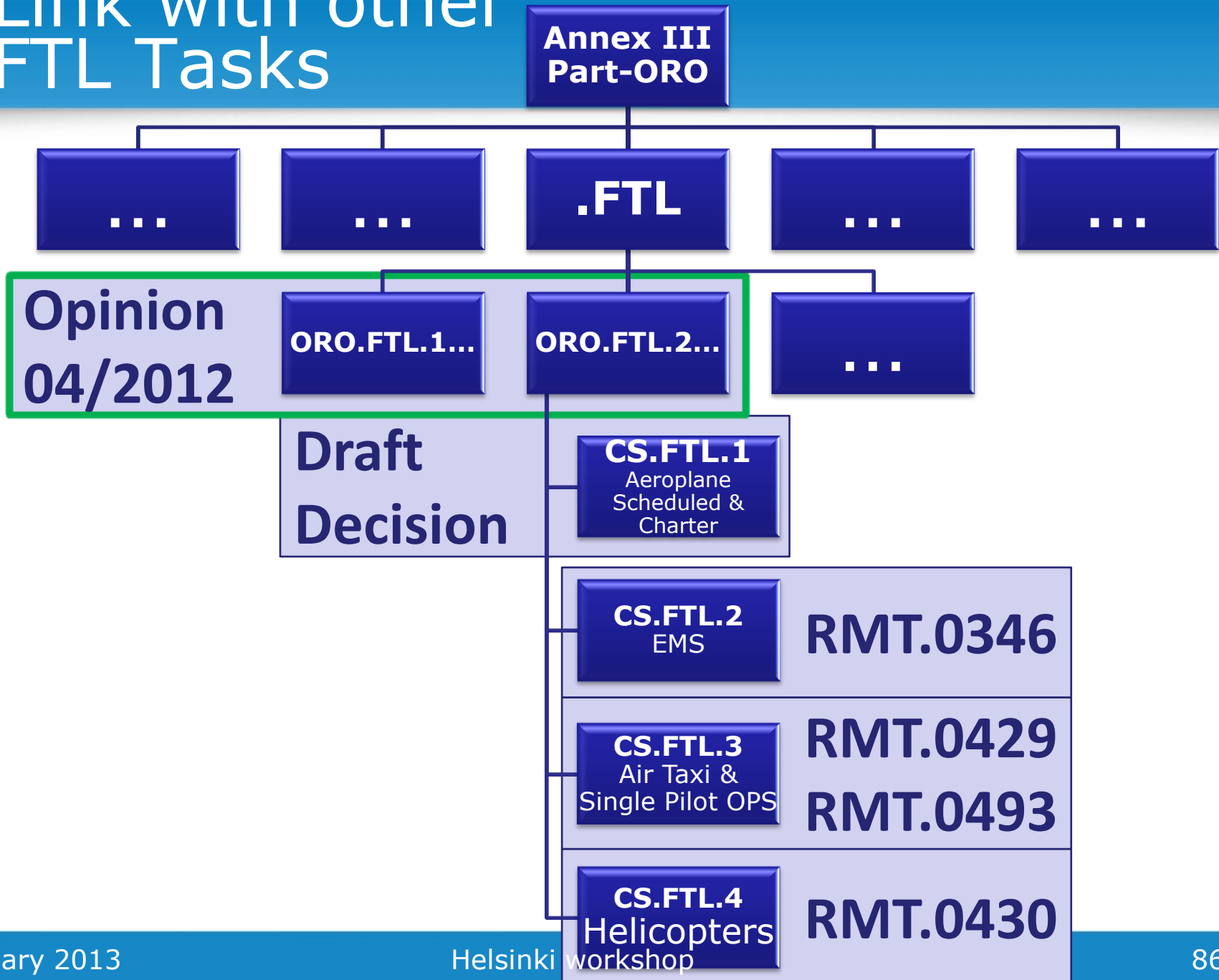



FTL – Section 1

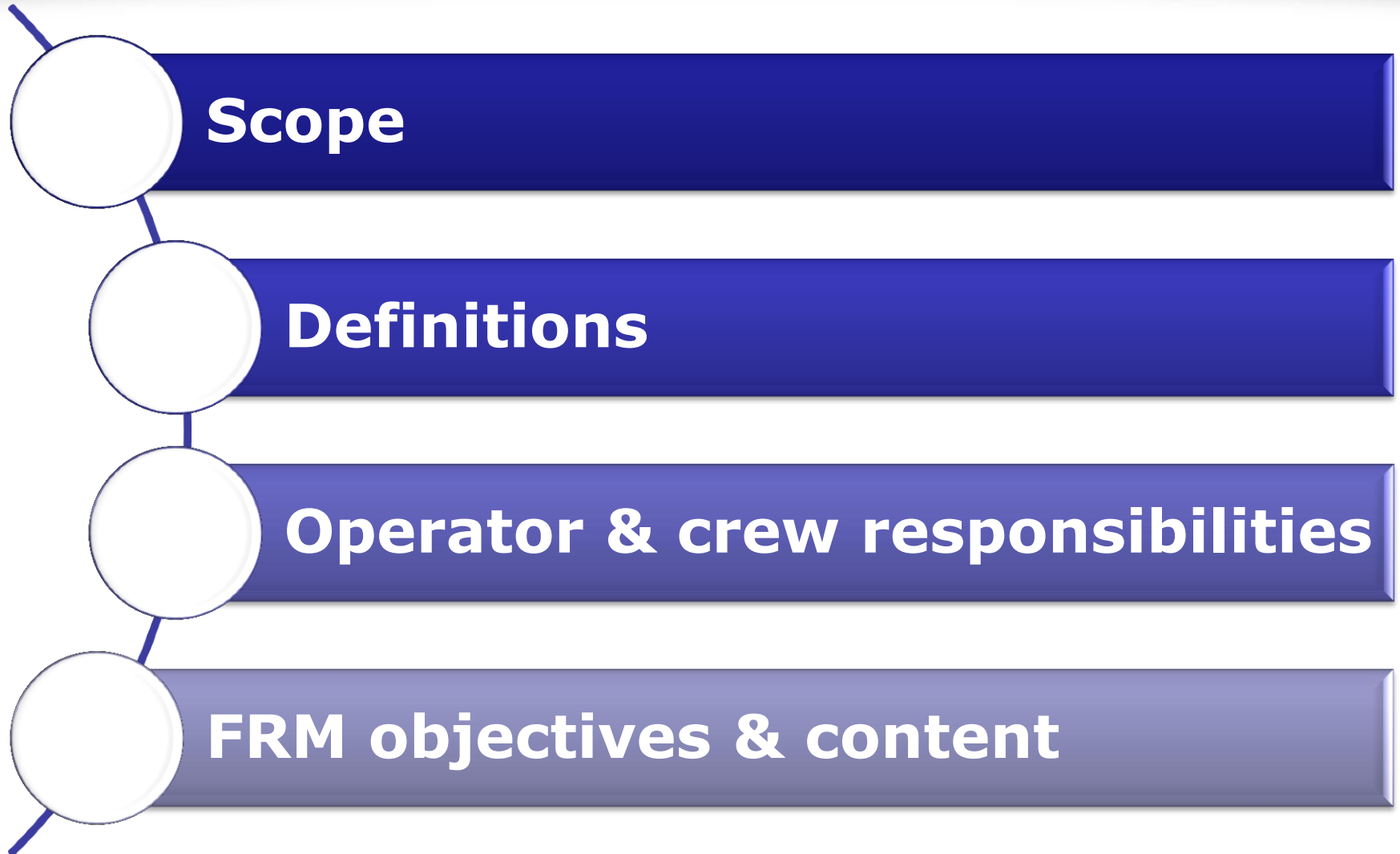



Technical requirements

Section 1 – Definitions (1)

Acclimatised

- ✓ Reference time for 48 hours after departure
- ✓ Afterwards 'un-known state of acclimatisation'
- ✓ Acclimatisation depends on how many TZ have been crossed and the time elapsed since reporting

Reference time

- ✓ To allow for operations based on local time for crew members with home bases in neighbouring time zones



Technical requirements

Section 1 – Definitions (2)

Accommodation

- ✓ **Used for airport standby and split duty**

Suitable accommodation

- ✓ **Used for split duty and back-to-back**

Rest facility

- ✓ **Criteria & objectives for in-flight rest facilities**

Fatigue risk management

Compliant with ICAO

Integrated in management system

Mandatory only for certain provisions

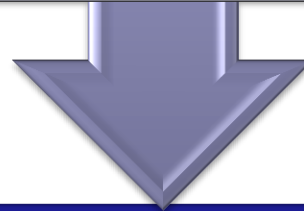

Fatigue management training

In Section 2

Mandatory for CAT operators



FTL – Section 2

Home base

FDP

Without extensions

Different reporting times CC

Conditions for FDP extensions

Cumulative limits

Standby

Rest periods

Nutrition

Record keeping



Technical requirements

Section 2 – Home base

Obligation to assign a home base

Single airport location

High degree of permanence

Additional rest for change of home base

IR

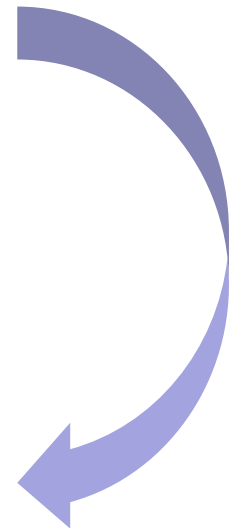

CS



Technical requirements

Section 2 – FDP

Start of FDP	1-2 Sectors	3 Sectors	4 Sectors	5 Sectors	6 Sectors	7 Sectors	8 Sectors	9 Sectors	10 Sectors
0600-1329	13:00	12:30	12:00	11:30	11:00	10:30	10:00	09:30	09:00
1330-1359	12:45	12:15	11:45	11:15	10:45	10:15	09:45	09:15	09:00
1400-1429	12:30	12:00	11:30	11:00	10:30	10:00	09:30	09:00	09:00
1430-1459	12:15	11:45	11:15	10:45	10:15	09:45	09:15	09:00	09:00
1500-1529	12:00	11:30	11:00	10:30	10:00	09:30	09:00	09:00	09:00
1530-1559	11:45	11:15	10:45	10:15	09:45	09:15	09:00	09:00	09:00
1600-1629	11:30	11:00	10:30	10:00	09:30	09:00	09:00	09:00	09:00
1630-1659	11:15	10:45	10:15	09:45	09:15	09:00	09:00	09:00	09:00
1700-0459	11:00	10:30	10:00	09:30	09:00	09:00	09:00	09:00	09:00
0500-0514	12:00	11:30	11:00	10:30	10:00	09:30	09:00	09:00	09:00
0515-0529	12:15	11:45	11:15	10:45	10:15	09:45	09:15	09:00	09:00
0530-0544	12:30	12:00	11:30	11:00	10:30	10:00	09:30	09:00	09:00
0545-0559	12:45	12:15	11:45	11:15	10:45	10:15	09:45	09:15	09:00

Consecutive night duties are limited to 4 sectors
 'Night duties' of ≥ 10 hours should be *managed*





Technical requirements

Section 2 – FDP extensions

CS

Start of FDP	1–2 sectors	3 sectors	4 sectors	5 sectors
0600–0614	Not allowed	Not allowed	Not allowed	Not allowed
0615–0629	13:15	12:45	12:15	11:45
0630–0644	13:30	13:00	12:30	12:00
0645–0659	13:45	13:15	12:45	12:15
0700–1329	14:00	13:30	13:00	12:30
1330–1359	13:45	13:15	12:45	12:15
1400–1429	13:30	13:00	12:30	12:00
1430–1459	13:15	12:45	12:15	Not allowed
1500–1529	13:00	12:30	12:00	Not allowed
1530–1559	12:45	12:15	11:45	Not allowed
1600–1629	12:30	12:00	11:30	Not allowed
1630–1659	12:15	Not allowed	Not allowed	Not allowed
1700–1729	12:00	Not allowed	Not allowed	Not allowed
1730–1759	11:45	Not allowed	Not allowed	Not allowed
1800–1829	11:30	Not allowed	Not allowed	Not allowed
1830–1859	11:15	Not allowed	Not allowed	Not allowed
1900–0359	Not allowed	Not allowed	Not allowed	Not allowed
0400–0414	Not allowed	Not allowed	Not allowed	Not allowed
0415–0429	Not allowed	Not allowed	Not allowed	Not allowed
0430–0444	Not allowed	Not allowed	Not allowed	Not allowed
0445–0459	Not allowed	Not allowed	Not allowed	Not allowed
0500–0514	Not allowed	Not allowed	Not allowed	Not allowed
0515–0529	Not allowed	Not allowed	Not allowed	Not allowed
0530–0544	Not allowed	Not allowed	Not allowed	Not allowed
0545–0559	Not allowed	Not allowed	Not allowed	Not allowed

Up to 2 times per 7 days

Additional rest:
 Pre- and post-flight + 2 hours
 Post-flight + 4 hours

Planned in advance

Not to be combined with:
 In-flight rest
 Split duty

Technical requirements Section 2 – Cumulative limits

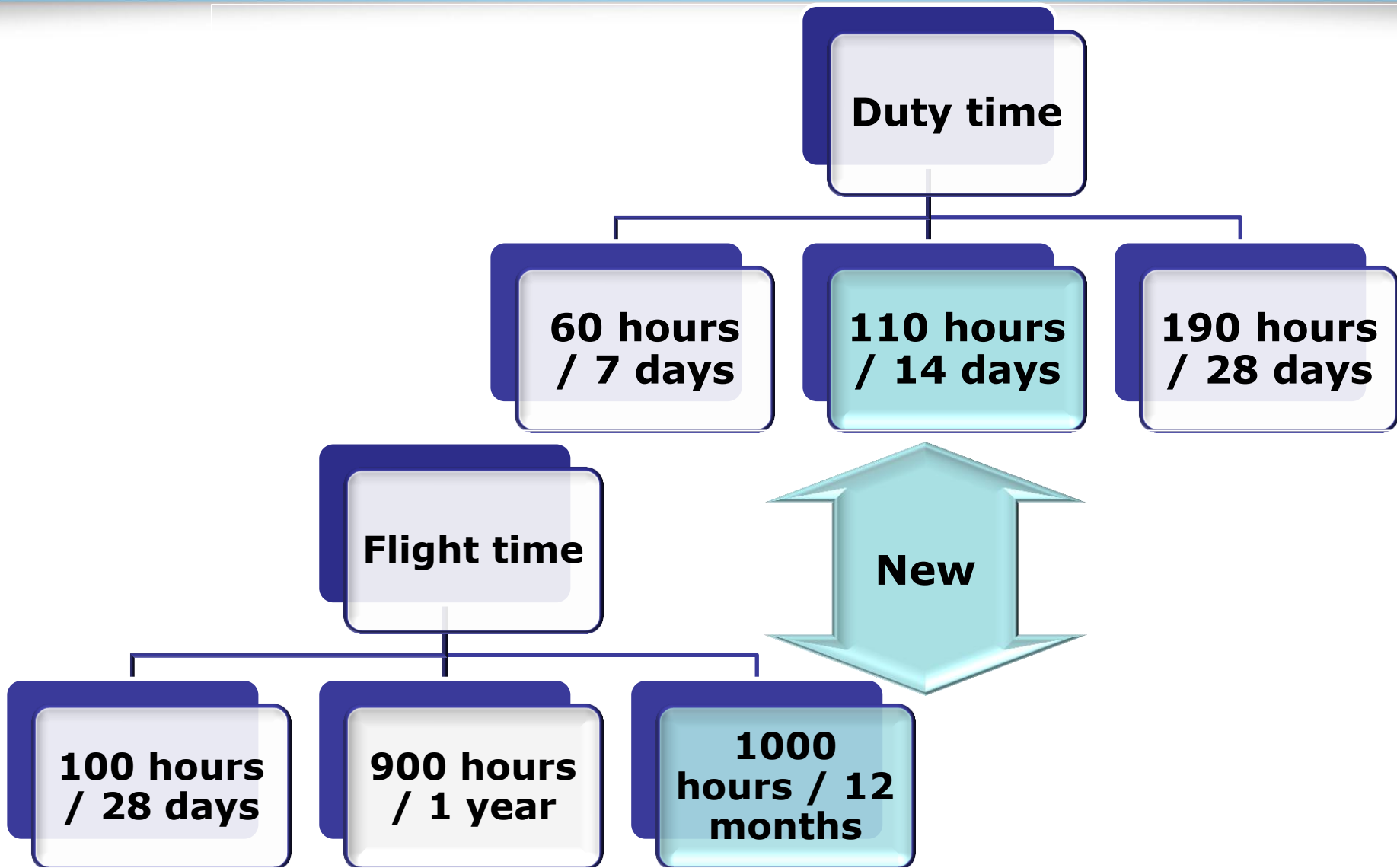

Technical requirements Section 2 – Rest

Minimum rest

Home base
12h or FDP

IR

Away
10h or FDP

Reduced rest

12h home base – 10h away

CS

IR

Recurrent recovery rest

36h incl. 2 local nights – 48h 2x/month

TZC

CS

Disruptive
schedules

CS

Home base
change

Split duty

not after reduced rest
break counts as FDP

IR

break \geq 3h

FDP increase
50% of break

(suitable)
accommodation

CS

CS

Not combined with in-flight rest

Technical requirements

Section 2 – Standby

**Standby & airport duty rostered
start & end defined & notified**

IR

CS

Other standby
25% duty
followed by rest
16h max
after 8h ↘ FDP
response time

Airport duty
100% FDP

IR

Accommodation
Airport standby
100% duty
16h cap
after 4h ↘ FDP
followed by rest

IR

CS

Reserve - 10h notification
- not duty
- not during rest



Subpart Q vs. Opinion 04/2012

Item	Q	EASA FTL	
Cumulative limits	60h duty/7 days 190h duty/28 days 100h block/28 days 900h block/calendar year	60h duty/7 days 110h duty/14 days 190h duty/28 days 100h flight/28 days 900h flight/calendar year 1000h flight/12 month ☺	++
FDP	13h day / 11h night -30min 3 rd – 6 th sector Extension night 11:45h	13h day / 11h night -30min 3 rd sector – 9h No extension night	= + +
Rest	12h or duty home base 10h or duty away 36h 2 local nights 2 nd local night exception	12h or duty home base 10h or duty away 36h 2 local nights 48h 2x/months No 2nd local night exception Disruptive schedules rest	= = = + + +



Key safety improvements (1)

General

- Harmonised standards

Home base

- Single airport location
- Additional rest upon change of home base

Cumulative fatigue

- Improved extended recovery rest
- Compensation for disruptive schedules



Key safety improvements (2)

FDP

- Extended time window for night restrictions
- No extensions during night hours
- In-flight rest extension based on high quality of in-flight rest facilities

Standby

- 'Cap' on combined duration of airport standby and FDP
- Other standby limited to 16 hours, FDP reduced after 8 hours
- Minimum rest after standby, 25% count as duty

FRM

- Mandatory fatigue management training
- Operator responsibilities

Publication dates	TOR	NPA	CRD	Opinion (or Decision if only CS)	Decision after Opinion
A & H EMS RMT.0346	2012 18 April	2013 Quarter 3	2014 Quarter 1	2015 Quarter 1	One year later
A Air Taxi RMT.0429	2012 21 August	2014 Quarter 1	2014 Quarter 3	2015 Quarter 3	One year later
H Other CAT ops by H RMT.0430	2013 Quarter 3	2015 Quarter 1	2015 Quarter 3	2016 Quarter 3	One year later



EUROPEAN AVIATION SAFETY AGENCY
AGENCE EUROPÉENNE DE LA SÉCURITÉ AÉRIENNE
EUROPÄISCHE AGENTUR FÜR FLUGSICHERHEIT

**Thank you for your
attention**

Comments and questions
welcome!

daniel.coutelier@easa.europa.eu

Your safety is our mission.
easa.europa.eu



EUROPEAN AVIATION SAFETY AGENCY
AGENCE EUROPÉENNE DE LA SÉCURITÉ AÉRIENNE
EUROPÄISCHE AGENTUR FÜR FLUGSICHERHEIT

10TH
ANNIVERSARY

- **Entry into force**
- **Transitioning**
- **Grandfathering**
- **Conversion of AOC**

Your safety is our mission.
easa.europa.eu



Entry into force

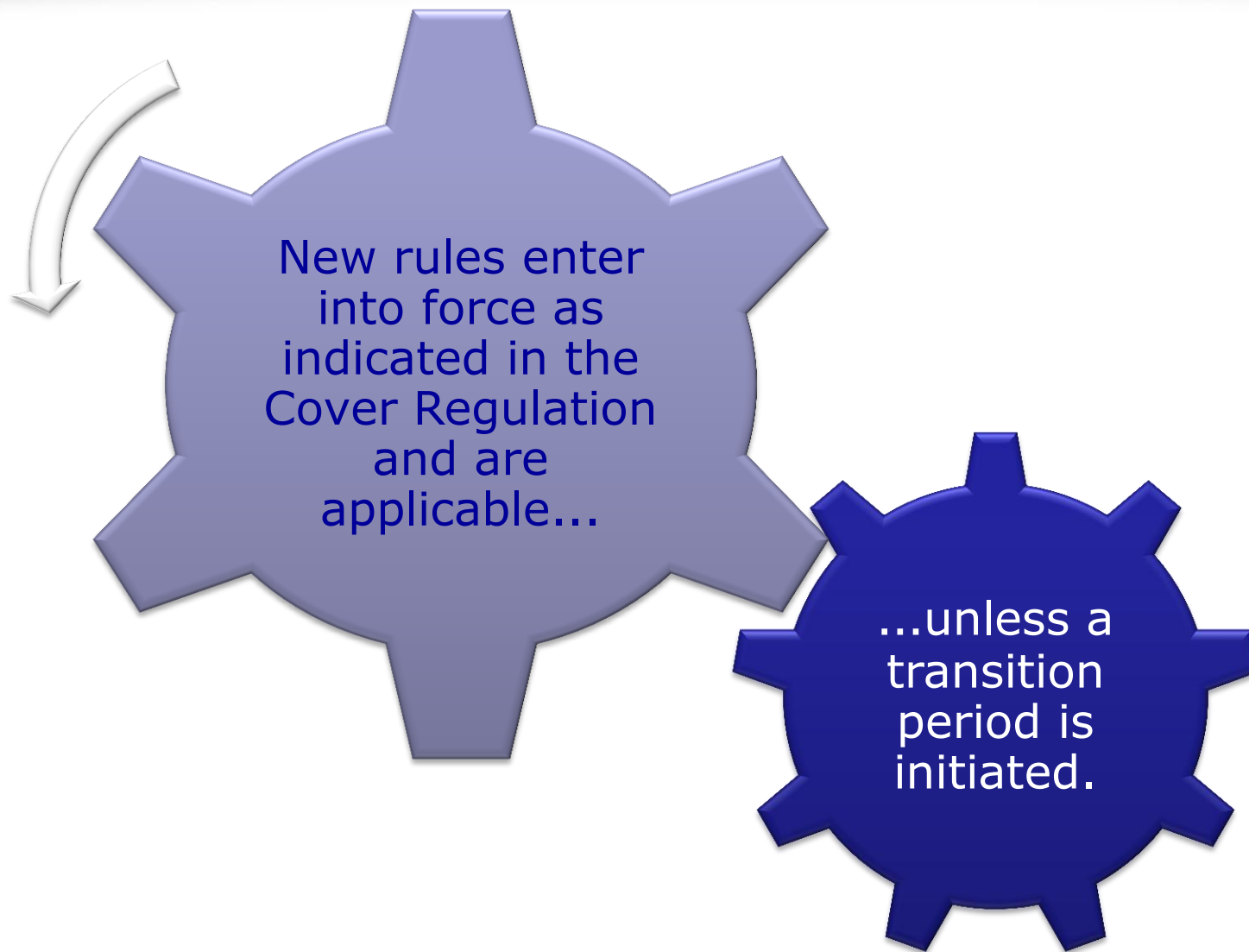

Transition periods (opt outs)

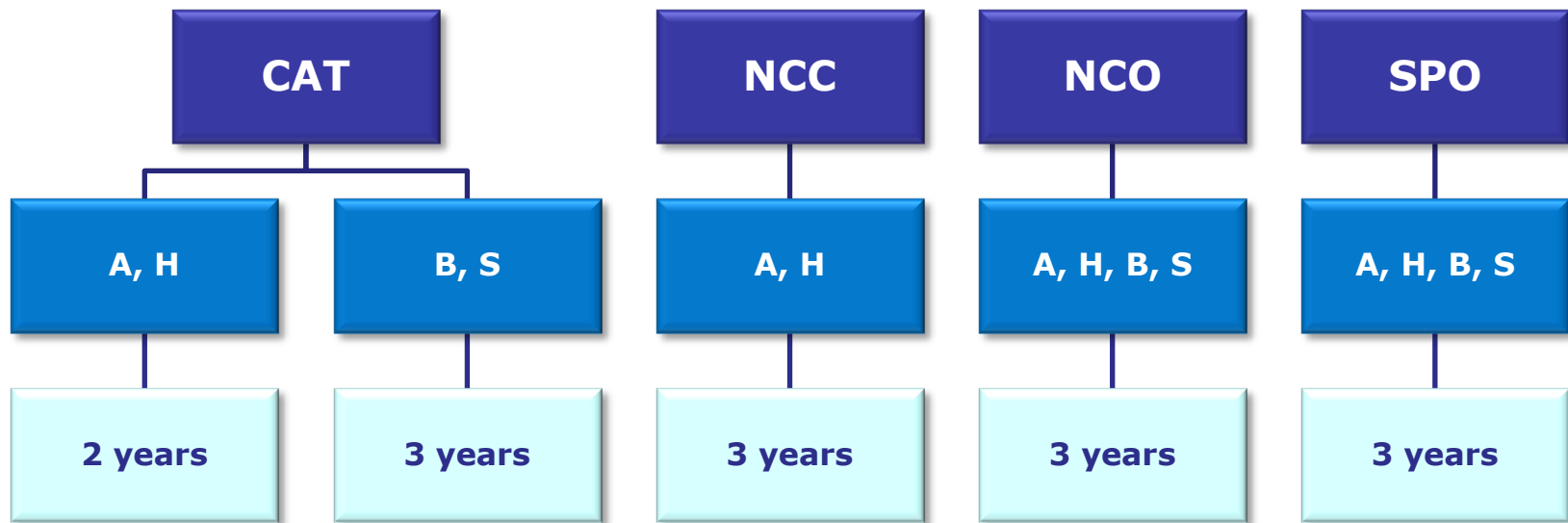

➤ MS shall;

- inform EC and EASA within 2 months if opt-out is used,
- describe reasons, duration, implementation programme.

Prior to applicability of Reg. 965/2012 (28 October 2014)

- Competent authority
 - Adapt management procedures, inspector's handbooks, certification software, etc.
 - Prepare a conversion report for CAT(H) in consultation with EASA, describing how and when CAT(H) AOCs holders will move to full compliance with new rules.
- Operators
 - Adapt management systems, operational procedures, training programmes, manuals.

Around 6 months before the transition period elapses

- Initial certification or AOC renewal to be based on new rules if likely not completed before end of opt-out period.



Grandfathering of EU-OPS AOC

- Grandfathering.
 - AOC issued in accordance with EU-OPS are deemed to be compliant with the new regulation.
- Differences between EU-OPS and new rules.
 - During opt-out phase adaptation of operator's management system, training programmes, procedures and manuals.
- New AOC format.
 - To be issued when the operator is fully compliant.



Conversion of JAR-OPS 3 (H) AOC

- MS to establish conversion report describing;
 - the national requirements on the basis of which the AOCs were issued,
 - the scope of privileges that were given to the operators,
 - the differences between the national requirements and the new rules,
 - how and when the operators will be required to ensure full compliance with new rules.
- New AOC.
 - To be issued when the operator is fully compliant.



EUROPEAN AVIATION SAFETY AGENCY
AGENCE EUROPÉENNE DE LA SÉCURITÉ AÉRIENNE
EUROPÄISCHE AGENTUR FÜR FLUGSICHERHEIT

10TH
ANNIVERSARY

Any Questions?

Your safety is our mission.
easa.europa.eu



EUROPEAN AVIATION SAFETY AGENCY
AGENCE EUROPÉENNE DE LA SÉCURITÉ AÉRIENNE
EUROPÄISCHE AGENTUR FÜR FLUGSICHERHEIT

10TH
ANNIVERSARY

Alternative means of compliance (AltMOC) – for CAT operations

Your safety is our mission.
easa.europa.eu



AltMOC: Principles

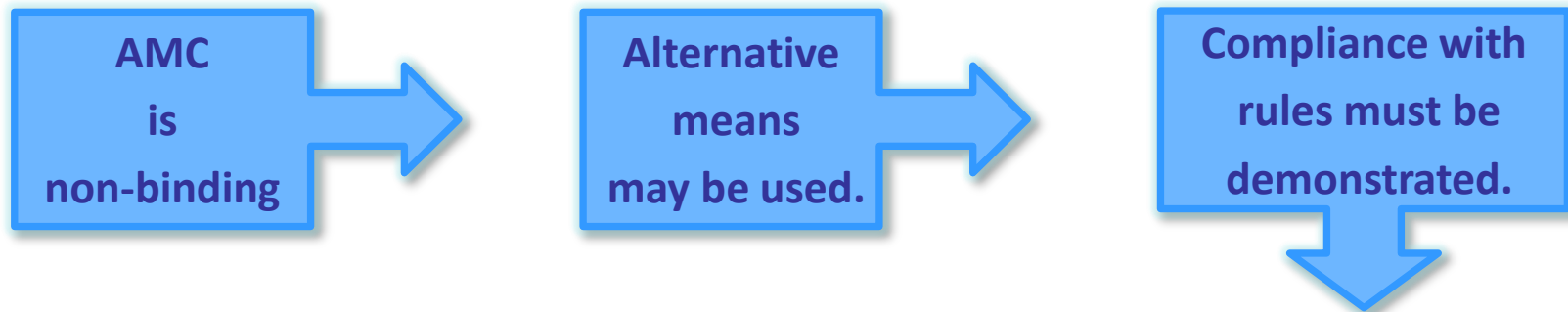

Process must be established on the level of the operator, NAA and the Agency to ensure:

- No negative effect on safety
 - Transparency
 - Harmonisation



- ▶ alternative means of compliance means (AltMOC)
 - ▶ those means that propose an alternative to an existing acceptable means of compliance or
 - ▶ those that propose new means to establish compliance with Regulation (EC) No 216/2008 and its Implementing Rules for which no associated AMC have been adopted by the Agency



AltMOC: The operator process

- ▶ When a CAT operator wishes to use an AltMOC to the AMC adopted by the Agency it shall provide the competent authority with a full description of the AltMOC
- ▶ The description shall include
 - ▶ any revisions to manuals or
 - ▶ procedures that may be relevant, as well as
 - ▶ an assessment demonstrating that the Implementing Rules are met
- ▶ The operator may implement these AltMOC subject to prior approval by the competent authority and upon receipt of the approval notification



AltMOC: The NAA process

NAA needs a system in place to evaluate the compliance of AltMOC with existing rules:

- for AltMOC proposed by organisations
- for AltMOC proposed by the NAA itself



AltMOC: The NAA process

NAA evaluates proposed AltMOC through:

- Analysis of documentation provided and, if needed, by inspection.

When AltMOC complies with the rule, NAA shall:

- Notify applicant and change certificate, if needed
- Notify the Agency of the content, including copies of relevant documents
- Inform other MS



NAA proposes
AltMOC itself

- Make it available to all organisations and persons under its oversight
- Notifies the Agency;
 - Full description of the AltMOC, including any revisions to procedures
- Demonstrate compliance with rules



Standardisation

- Risk based approach

Rulemaking

- Recurrent task
- Simplified procedure



Agency receives notification from NAA

Information included in database.

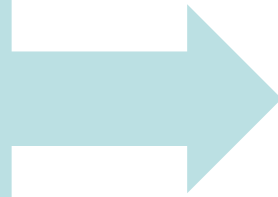

Quarterly review by focal points in S & R



- Identification of significant AltMOC, requiring further assessment
- Statistical report to S & R management



AltMOC: The Agency process

Significant
AltMOC reviewed
by internal
experts:

- Compliance with rules
- Regularity of procedure

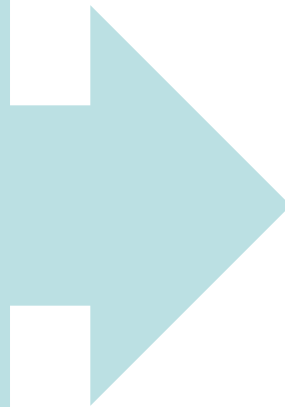

Input to
Standardisation:
for use during
Standardisation visits

Input to Rulemaking:
for possible new
rulemaking task



➤ References

- Definition defined in Annex I – Definitions
- ARO.GEN.120 Means of compliance
- ARO.GEN.220 Record-keeping
- ORO.GEN.120 Means of compliance



EUROPEAN AVIATION SAFETY AGENCY
AGENCE EUROPÉENNE DE LA SÉCURITÉ AÉRIENNE
EUROPÄISCHE AGENTUR FÜR FLUGSICHERHEIT

10TH
ANNIVERSARY

Any Questions?

Your safety is our mission.
easa.europa.eu



EUROPEAN AVIATION SAFETY AGENCY
AGENCE EUROPÉENNE DE LA SÉCURITÉ AÉRIENNE
EUROPÄISCHE AGENTUR FÜR FLUGSICHERHEIT

10TH
ANNIVERSARY

On-going rulemaking tasks

- Volcanic ash
- EFB

Your safety is our mission.
easa.europa.eu



ICAO International Volcanic Ash Task Force

- **Started in 2010 and ended in June 2012 after 4 meetings**
- **4 sub-groups were created**
 - Science SG
 - Airworthiness SG
 - Air Traffic Management SG
 - Volcano watch co-ordination SG
- **Tasks:**
 - Review global aviation standards related to VA
 - Improve guidance material when necessary/possible
- **Final report was issued with 24 recommendations**
 - Available on ICAO website
 - [http://www.icao.int/safety/meteorology/ivatf/Meeting MetaData/IVATF-4.Final Report.pdf](http://www.icao.int/safety/meteorology/ivatf/Meeting%20MetaData/IVATF-4.Final%20Report.pdf)

- **VA SRA methodology further refined (Resulted in Doc 9974, subset of SMS).**
- **VA detection improvement (radars, LIDAR, satellite,...).**
- **Crisis management and communication.**
- **Update of Doc 9691 (Manual on Volcanic Ash, Radioactive Material and Toxic Chemical Clouds).**
- **Not achieved:**
 - Definition of visible ash.
 - Full standardisation of VAAC products.
 - Definition of tolerance of products to VA.

3 stages approach (3 rulemaking tasks):

1. Operational SRA guidance.
2. Information to Operators. TCH to support operators' SRAs by assessing the susceptibility of their products to volcanic clouds.
3. Airworthiness limitations for engine VA ingestion.



Task 1: Operational SRA guidance

RMT.0460 for operational guidance:

Guidance Material to develop SRA for flight operations with known or forecasted volcanic cloud contamination.

Objectives:

Based on ICAO DOC 9974;

Develop AMC and GM to Part-ORO/ORA;

➤ to provide guidance on how to develop VA SRA, and AMC and GM to Part ARO/ARA;

➤ to provide guidance on how to assess VA SRA.





Management system requirements

ORO.GEN.200 Management system

- (a) The operator shall establish, implement and maintain a management system that includes:
- (1) clearly defined lines of responsibility and accountability throughout the operator, including a direct safety accountability of the accountable manager;
 - (2) a description of the overall philosophies and principles of the operator with regard to safety, referred to as the safety policy;
 - (3) the identification of aviation safety hazards entailed by the activities of the operator, their evaluation and the management of associated risks, including taking actions to mitigate the risk and verify their effectiveness;
 - (4) maintaining personnel trained and competent to perform their tasks;
 - (5) documentation of all management system key processes, including a process for making personnel aware of their responsibilities and the procedure for amending this documentation;
 - (6) a function to monitor compliance of the operator with the relevant requirements. Compliance monitoring shall include a feedback system of findings to the accountable manager to ensure effective implementation of corrective actions as necessary; and
 - (7) any additional requirements that are prescribed in the relevant Subparts of this Annex or other applicable Annexes.
- (b) The management system shall correspond to the size of the operator and the nature and complexity of its activities, taking into account the hazards and associated risks inherent in these activities.



OPS rules impacted and applicability

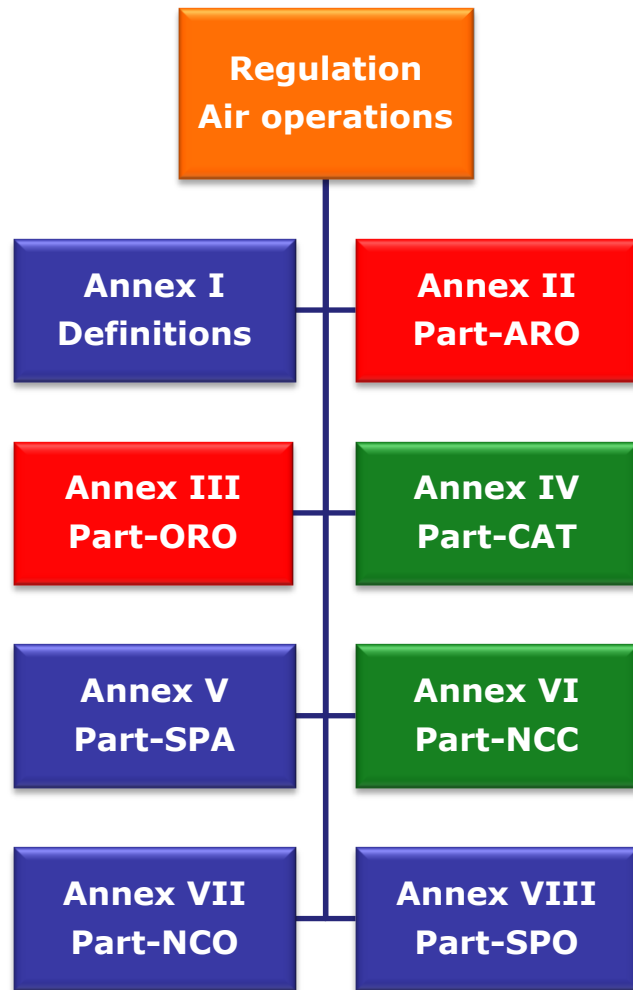

- **Part-ARO:** Authority requirements - OPS
- **Part-ORO:** Organisation requirements - OPS
- **Part-CAT:** Commercial air transport operations

- **Part-NCC:** non-commercial operations with complex motor-powered aircraft (CMPA)



Aircrew rules impacted and applicability

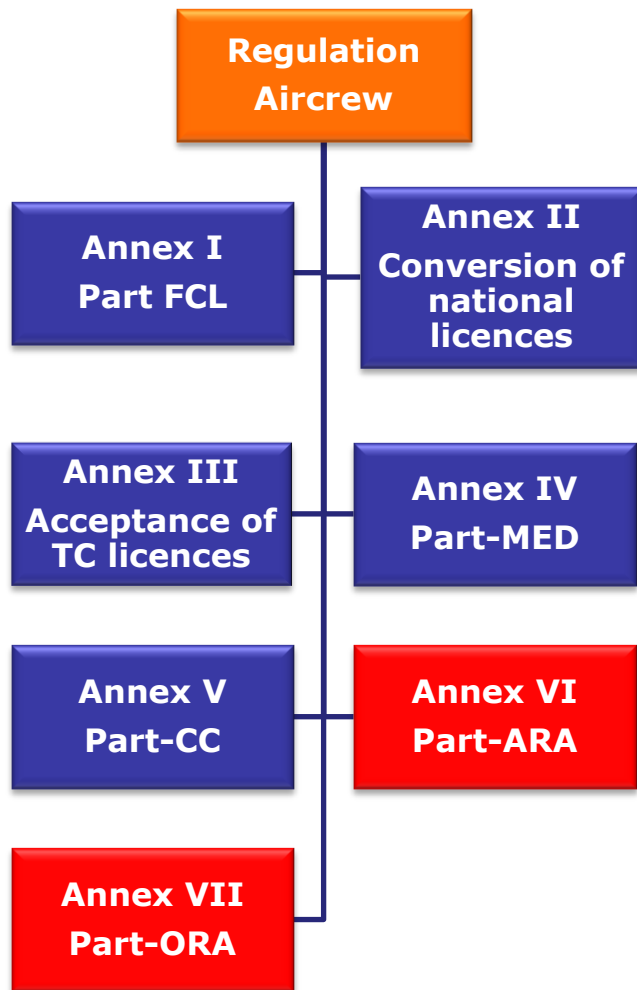

Amended Regulation 1178/2011 + Decisions 2012/06-07/R

- **Part-ARA:** Authority requirements - OPS
- **Part-ORA:** Organisation requirements – OPS



RMT.0460: Status



ToR
Terms of
Reference



NPA
Notice of Proposed
Amendment



CRD
Comment Response
Document

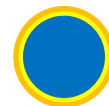

Decision
AMC/GM

Objectives
Method
Timeline

ToR published
19/06/2012

Text proposal
Public
consultation

NPA 2012-07
19/07/2012

Individual
answers
Amended text

CRD planned
Q4 2012

Decision adopted
by EASA

Decision
planned
Q1 2013

CRD and Decision Q1 2013 due to new rulemaking process.

RMT.0460: comments received

- 80 comments received
- 22 commenters

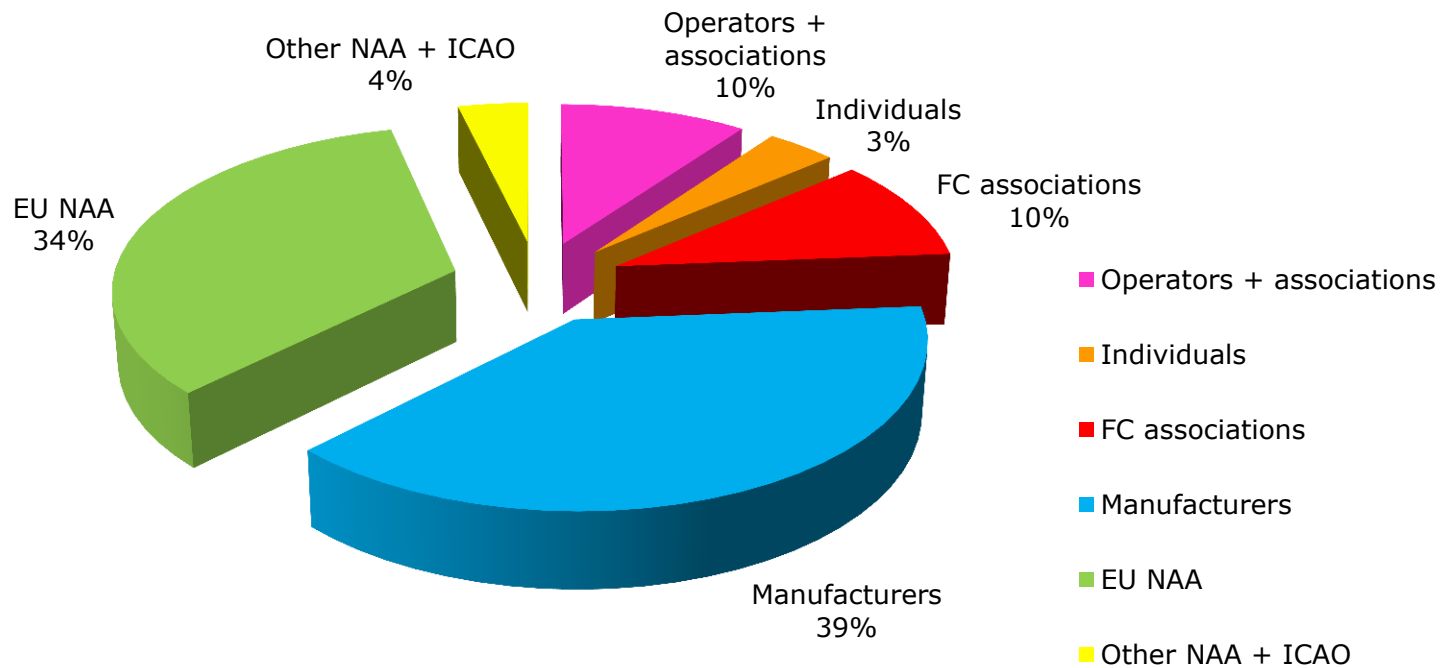

Summary of main comments to the NPA

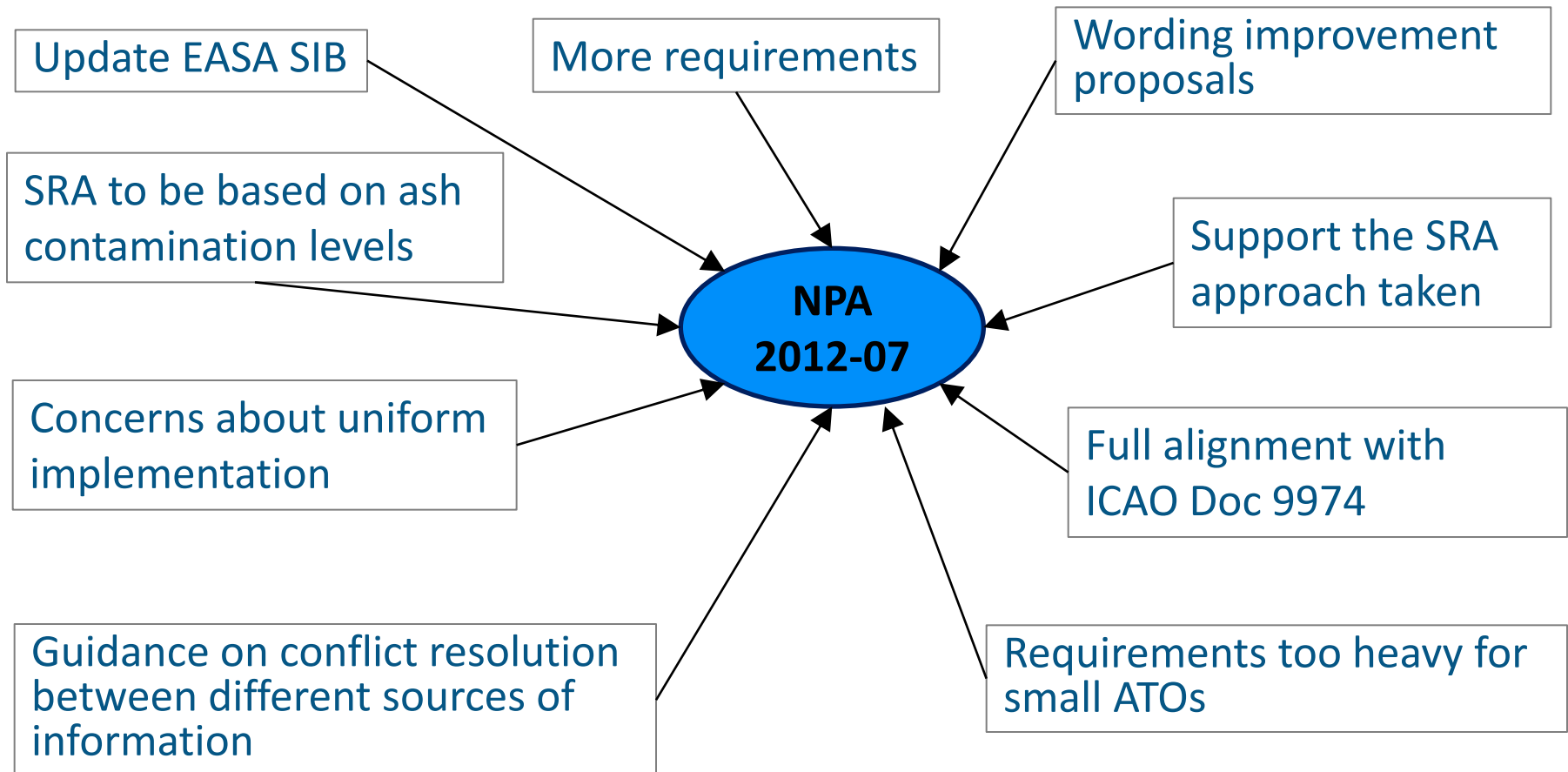



Task 2: Information to Operators

Task RMT.0364 *Certification Specifications for Aircraft and Engines* – *Volcanic ash.*

Objectives:

- » Change CSs to better reflect existing TCH obligations to supply information on VA.
- » To propose changes to CS-23, CS-25, CS-27, CS-29, CS-E, CS-P, CS-APU.
- » To support operator when developing their VA SRAs.

Status:

- » NPA 2011-17 publication 03/09/2011.
- » CRD 2011-17 publication 08/10/2012.
- » Expected completion – 2013.

Task 3: Airworthiness limitations for engine VA ingestion

Task RMT.0364: *Certification Specifications for Aircraft and Engines - Volcanic ash ingestion in turbine engines.*

Objectives:

- To look at possible long-term solutions to flight a known VA environment.
- Aims to establish;
 - whether VA SRA principle is sufficient,
 - if potential benefits can be achieved with the possible use of airworthiness limits,
 - what would be the cost and impacts,
 - if it's practical to define limits and tests.

Status:

- A-NPA 2012-21 published 28/11/2012.
- Comment period ends 28/02/2013.
- Estimated publication of Decision in Mid-2013?



Actual situation:

- VA SRA recommended through SIB 2010-17.
- MS are recommended to notify EASA of VA SRA acceptance.
- All VA SRA accepted are uploaded on a file accessible to all MS.

Short term situation:

- First OPS rules package was published 25/10/12.
- Management system required for all CAT operators to obtain an AOC (ORO.AOC.100).
- ORO.GEN.200: All hazards need to be identified and risks managed.
- Within Europe, mutual recognition of AOC.
- Outside Europe: EASA management system requirements are compliant with ICAO Annex 6 SMS requirements.



EUROPEAN AVIATION SAFETY AGENCY
AGENCE EUROPÉENNE DE LA SÉCURITÉ AÉRIENNE
EUROPÄISCHE AGENTUR FÜR FLUGSICHERHEIT

10TH
ANNIVERSARY

Any Questions?

Your safety is our mission.
easa.europa.eu



EUROPEAN AVIATION SAFETY AGENCY
AGENCE EUROPÉENNE DE LA SÉCURITÉ AÉRIENNE
EUROPÄISCHE AGENTUR FÜR FLUGSICHERHEIT

10TH
ANNIVERSARY

Electronic Flight Bag (EFB)

Your safety is our mission.
easa.europa.eu



History and status of the EFB task

- **Issue 1 of the ToR published Dec 2006**
 - To transpose JAA TGL 36
 - Consider FAA AC 120-76A
- **Drafting Group established Jan 2007**
- **NPA originally planned June 2007 (i.e. before first extension)**
- **NPA 2012-02 has been published in March 2012**
- **CRD 2012-xxx planned in the first half of 2013**
- **Opinion/Decision expected end 2013/beginning 2014**



- **General**

- Clarification between airworthiness and OPS
 - . AMC20-25 text reorganised
 - . Long term view: split AMC 20-25 into 2 AMCs (AMC for OPS + separate rules for airworthiness)
- Evaluation of type B application done by EASA
 - . Only on a voluntary basis, as it is already the case
- Enhance the EFB administrator requirements
 - . Experience and knowledge requirements introduced
 - . Responsibilities clarified
- Clarification of the update process
 - . Management of minor updates





Summary of main comments received (2/2)

• **EFB classes**

- Enhanced definitions Of EFB classes
 - . Only 2 EFB classes are kept (portable and installed)
- Data connectivity for class 2 EFB
 - . Provisions has been added for such connectivity under specific conditions
- Use of viewable stowage
- Sharing of installed resources with class 2 EFB (keyboard,...)

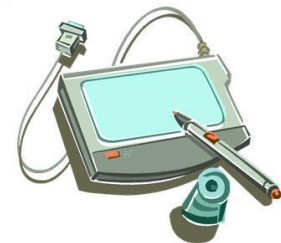

• **EFB applications**

- Enhanced Type A and B definitions
- Type C application removed as potential EFB application
- AMMD included in type B applications list
- Clarification of non-EFB software



- ❑ **Workshop organised with TAG members on April 18th**
- ❑ **Publication of CRD with individual answers to comments, proposal of revised text (opinion+AMC20-25+ETSO)**
- ❑ **Possibility to 'react' to CRD kept since complex and controversial task and task initiated before the new RM process**
- ❑ **Publication of Opinion/Decisions end 2013/beginning 2014**
- ❑ **Decisions will be adapted to be adopted simultaneously**





EUROPEAN AVIATION SAFETY AGENCY
AGENCE EUROPÉENNE DE LA SÉCURITÉ AÉRIENNE
EUROPÄISCHE AGENTUR FÜR FLUGSICHERHEIT

10TH
ANNIVERSARY

Any Questions?

Your safety is our mission.
easa.europa.eu



EUROPEAN AVIATION SAFETY AGENCY
AGENCE EUROPÉENNE DE LA SÉCURITÉ AÉRIENNE
EUROPÄISCHE AGENTUR FÜR FLUGSICHERHEIT

10TH
ANNIVERSARY

Additional on-going rulemaking tasks

Your safety is our mission.
easa.europa.eu



EASA rulemaking process (simplified)

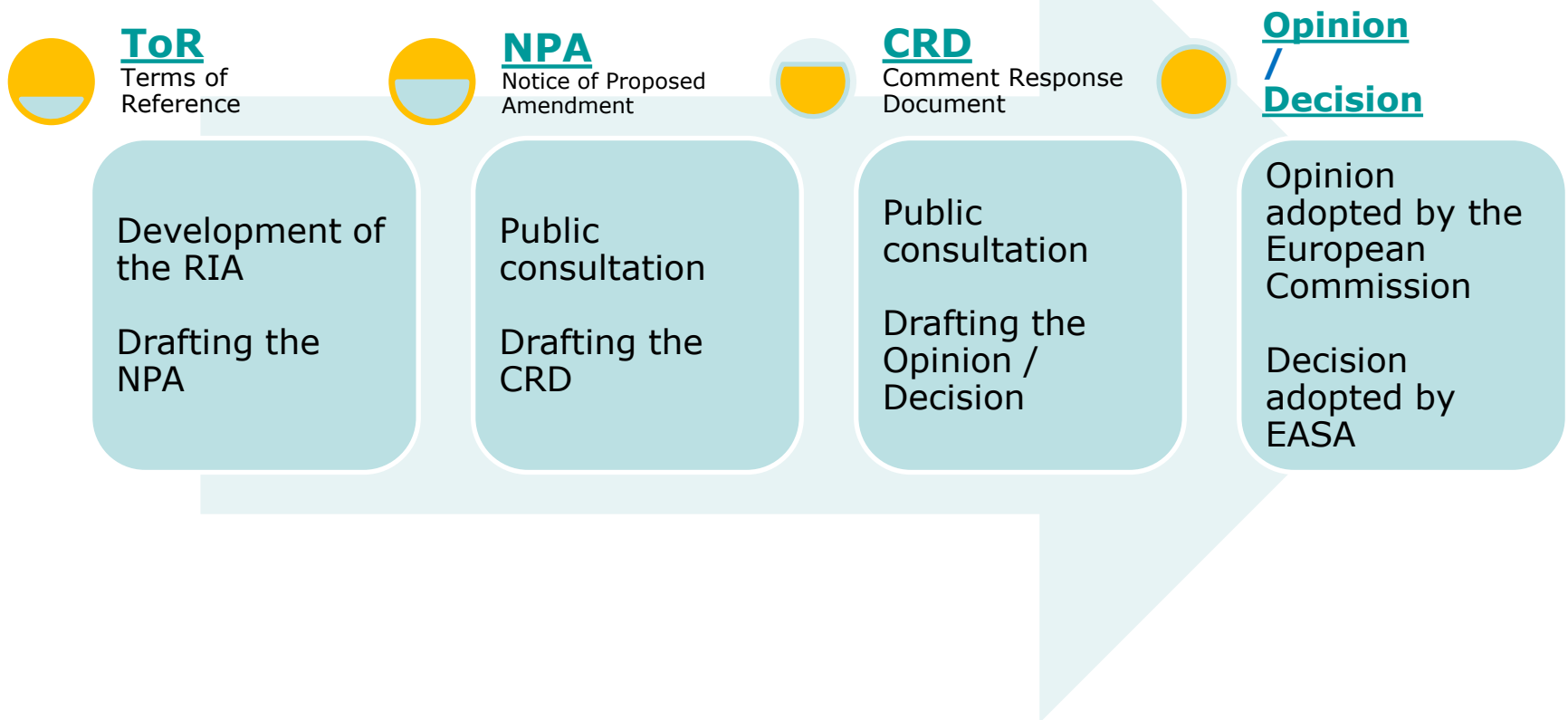

- ▶ **Sterile Flight Deck Procedures (RMT.0416, 0417)**
 - ▶ Comment Response Document (CRD) to be published 1q 2013
 - ▶ Opinion (final rule) expected before end 2013
- ▶ **Maintenance check flights (RMT.0393, 0344)**
 - ▶ CRD to be published 3q 2013

▶ **Transfer of JAA cabin safety tasks (RMT.0327, 0328)**

- ▶ Incapacitation and replacement of senior cabin crew
- ▶ Communication between a person on board the aeroplane and aerodrome
- ▶ emergency services during ground operations with passengers on board
- ▶ and in the absence of flight crew members
- ▶ CRD to be published 1q 2013
- ▶ Opinion (final rule) 3q 2013

- ▶ **Notice of Proposed Amendments (NPA) under preparation:**
 - ▶ Helicopter offshore operations (RMT.0409, 0410) - 1q 2013
 - ▶ Additional guidance material and requirements ramp inspections – 1q 2013
 - ▶ FTL for CAT Emergency Medical Services (A+H) (RMT.0346) – 3q 2013
 - ▶ Carriage of special categories of passengers (RMT.0269, 0270) – 3q 2013
 - ▶ PBN operational approvals (RMT.0256, 0257) – 3q 2013
 - » Review necessity for particularly general aviation
 - » Enforce pilot training requirements

➤ **Notice of Proposed Amendments (NPA) under preparation:**

- Commercial air transportation aeroplane operations single engine IMC (RMT.0232, 0233) – 4q 2013
- Updating of existing recorder installations and equipment (RMT.0400, 0401) - 4q 2013
 - ULB 90 days
 - CVR recording duration 2 hours
 - Discontinuation of magnetic tape recorders
 - carriage of low-frequency, long-range ULBs
- Runway overrun protection system (RMT.0047, 0569, 0570) – 1/2q 2013

- ▶ **Other on-going tasks (NPA publication 2014):**
 - ▶ Crew resource management (RMT.0411)
 - ▶ HEMS performance and public interest site (RMT.0325, 0326)
 - ▶ Flights of design and production organisations (RMT.0348, 0349)
 - ▶ FTL for CAT operations - air taxi and single-pilot operations (aeroplane) (RMT.0429)
 - ▶ Helicopter height velocity diagram (RMT.0132, 0515)

➤ **Tasks to be initiated 2013:**

- New PBN applications (RMT.0519, 0520) - 1q 2013
- Updating authority and organisation requirements (RMT.0516, 0517)
- FTL requirements for CAT operations for helicopters (RMT.0430)
- Passenger seating and briefing (RMT.0575, 0576)
- Prediction of windshear for aeroplane CAT operations (IRs) (RMT.0369, 0370)
- Operator's description of non-revenue flights (RMT.0352, 0353)
- Carbon monoxide detector on board all piston-engined aircraft (RMT.0329, 0330)

➤ **Tasks to be initiated 2013:**

- Recorders for small aircraft (RMT.0271, 0272)
- Remotely piloted aircraft (RMT.0229, 0230)
- TAWS for smaller aircraft (RMT.0371, 0372)



EUROPEAN AVIATION SAFETY AGENCY
AGENCE EUROPÉENNE DE LA SÉCURITÉ AÉRIENNE
EUROPÄISCHE AGENTUR FÜR FLUGSICHERHEIT

10TH
ANNIVERSARY

Any Questions?

Your safety is our mission.
easa.europa.eu



EUROPEAN AVIATION SAFETY AGENCY
AGENCE EUROPÉENNE DE LA SÉCURITÉ AÉRIENNE
EUROPÄISCHE AGENTUR FÜR FLUGSICHERHEIT

10TH
ANNIVERSARY

Flight Standards Mini-Website

EASA

<http://easa.europa.eu/flightstandards/index.html>

Air_Ops@easa.europa.eu

Your safety is our mission.
easa.europa.eu



Flight Standards mini-website content

- **Stand-alone Flight Standards website within EASA main website**
- **General aviation information**
- **FAQ – questions and answers on:**
 - General issues
 - Crew Licensing
 - Air Operations
 - Medical
 - Third country Operators
 - News & Events:
 - <http://easa.europa.eu/flightstandards/latestnews.html>



Cross reference table

- **Comparison EASA OPS with JAR-OPS 3 and EU-OPS**
- **Difference statements**
- **Status: version 02 was published at the end of 2012**

• http://easa.europa.eu/flightstandards/doc/Cross%20reference%20table_version02.xlsx

Sec #	European rule IR/AMC/GM	European rule reference	European rule title	EU-OPS/JAR-OPS3 IR/ACJ/AMC/IEM	EU-OPS rule reference	JAR-OPS3 rule reference	EU-OPS/JAR-OPS3 rule title	Difference to EU-OPS Classification	Difference to EU-OPS Description	Difference to JAR-OPS3 Classification	Difference to JAR-OPS3 Description
1	IR	Annex I	Definitions for terms used in Annexes II to VII	IR	-	3.005(f) - Appendix 1, (a)(1)	Operations for small helicopters (VFR day only)	-	-	Amended	The definition in EASA OPS is more specific. Small helicopters (as defined in JAR-OPS 1) are treated as non-complex helicopters (in the sense of the Basic Regulation).
1	IR	Annex I	Definitions for terms used in Annexes II to VII	IR	1.037(a)4.	-	Accident prevention and flight safety programme	No change	Definition for 'flight data monitoring' extracted from EU-OPS rule	-	-
1	IR	Annex I	Definitions for terms used in Annexes II to VII	IR	1.1150(a)1, 4 - 6, 15	3.1150(a)(1), (3), (4), (15)	Terminology	No change	-	No change	-
1	IR	Annex I	Definitions for terms used in Annexes II to VII	IR	1.165(a)	3.165(a)	Leasing	Amended	The terms are aligned with Art. 2 of Reg. (EC) No 1008/2008	Amended	The terms are aligned with Art. 2 of Reg. (EC) No 1008/2008
1	IR	Annex I	Definitions for terms used in Annexes II to VII	ACJ	1.345 2.a, 2.g, 2.k	-	Ice and other contaminants	Amended	Anti-icing' and 'de-icing' refer to aircraft, not only aeroplanes. 'Hold-over time' aligns with ICAO Doc 9640, 2nd ed..	New	Definitions from EU-OPS refer to aircraft, not aeroplanes and therefore apply to helicopters too.
1	IR	Annex I	Definitions for terms used in Annexes II to VII	IR	1.430 - Appendix 1 (f)1. (i), (ii)	3.430 - Appendix 1, (d)(1)	Precision approach — Category II and other than Standard Category II operations	No change	-	Amended	The scope of OTS CAT II has been extended to helicopter operations.
1	IR	Annex I	Definitions for terms used in Annexes II to VII	IR	1.430 - Appendix 1 (New), (b)(3)	-	Aerodrome operating minima	Amended	Approach procedure with vertical guidance': does not provide for the authority to approve lower minima [Placed in main Annex I with Opinion 1/2012]	-	-
1	IR	Annex I	Definitions for terms used in Annexes II to VII	IR	1.430 - Appendix 1 (New), (b)(1)	-	Aerodrome operating minima	Amended	CAT I approach operation': GNSS using SBAS is included	-	-



Rule structure:

<http://easa.europa.eu/flightstandards/structure.html>

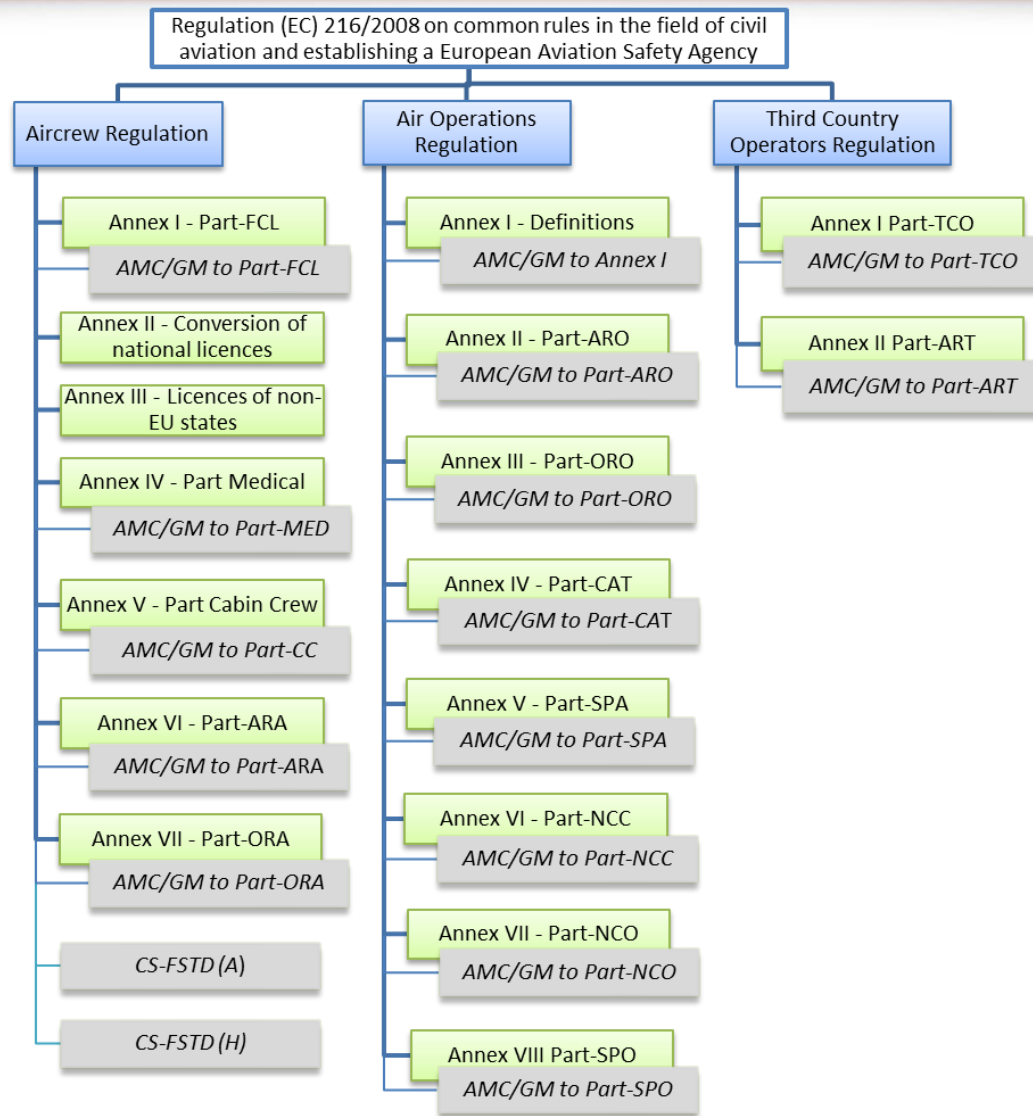



Easy ways to stay up to date

- **EASA official publications [weblink](#)**
 - Filter your search
 - Implementing rules (IR)
 - AMC/Guidance Material/Certification Specifications (CS)

- **Technical publications website**
 - receive automatic email notification [updates](#)

- **General publications website**
 - receive automatic email [notifications](#)

- **List of Member State [Opt-outs](#) to OPS Regulation 965/2012**



EASA Technical Publications

New publications in 2013!



Part-21

Airworthiness and Environmental Certification

Updated Part-21 rules in the Technical Publications format.

Will soon be available as:
- Printed handbook & CD
- CD only

To keep up-to-date, you can subscribe to our Technical Publications webpage
<http://easa.europa.eu/technical-publications>



AIR OPS

Air Operations, first package

AIR OPS rules in the Technical Publications format (Annexes I to V, including Definitions, Authority Requirements, Organisations Requirements, Commercial Air Transport and Specific Approvals)

Will soon be available as CD

To keep up-to-date, you can subscribe to our Technical Publications webpage
<http://easa.europa.eu/technical-publications>

 Part-M, Part-145 and Part-66 are still up-to-date and available!

Further Technical Publications are in planning and include FCL and ADR rules. All EASA Technical Publications are available from the EU Bookshop via the EASA Technical Publications webpage.

To keep up-to-date, you can subscribe to our Technical Publications webpage
<http://easa.europa.eu/technical-publications>



EUROPEAN AVIATION SAFETY AGENCY
AGENCE EUROPÉENNE DE LA SÉCURITÉ AÉRIENNE
EUROPÄISCHE AGENTUR FÜR FLUGSICHERHEIT

**10TH
ANNIVERSARY**

**Flight Standards Department
Any Questions?**

Your Safety is our Mission
air_ops@easa.europa.eu

<http://www.easa.europa.eu/flightstandards/>

Your safety is our mission.
easa.europa.eu